



The New DigitalMicroscope Series

Leica DM

for Life Sciences

Simply Microscopy!
Perfection At Work

Leica
MICROSYSTEMS

Intelligence
Comfort
Brilliance
Integration

This is why you entered science.

It's what you work for every day.

Now let the new Leica DM DigitalMicroscope help you make that brilliant discovery!

Perfection At Work - Simply Microscopy!

The Exterior: New Technology in a New Design

The first thing you will notice about our new DigitalMicroscopes is their new design*: clear, attractive contours. Enough, for now, of the outside of the microscope.

Looking Through the Microscope: Fascinating Insights

Once you have seen a sample through one of these new microscopes, you will never want to use any other. No microscope in this class can offer better image brilliance, field depth and contrast.

Just Rely On Your Intuition

Our new Leica DM DigitalMicroscope series provides the answers to many of our customers problems. One of the most frequently voiced requests was to lighten the workload. So we found ways of doing a lot of the work for you. You can operate the microscope intuitively and easily automate complex routines to suit your specific needs.

Experts Call it Ergonomics. We Call it User-Friendly

Ergonomics is a word often used. On our new microscopes you can actually feel it. Cooperating closely with the Fraunhofer Institute**, our designers have not only outperformed the latest technological standards but also all the ergonomic specifications.

* registered Design DE 402 04 845; patented DE 101 26 291

** The Fraunhofer Institute IAO (Stuttgart, Germany) investigates ergonomic aspects of various products. In cooperation with their industrial partners they develop industrial designs to suit highest ergonomic demands.





Your Benefits

Intelligence



An impression of clarity wherever you look: Customer-specific illumination and diaphragm adjustments can be made on the front left side of the microscope.



Left: The new LeicaScreen on the DM6000B with touch-sensitive LCD display. The clearly designed menu structure uses internationally familiar pictograms* instead of language for intuitive operation. Right: The familiar Leica SmartMove remote control. You can use the remote control unit to control all 3 axes of the microscope (x,y: stage, z: focus). You can also program user-defined microscope functions and assign them to the 4 function buttons.

* registered Design DE 403 000 51

Automatic Diaphragm Adjustment

Our new DigitalMicroscopes automatically recognize the contrasting technique and objective that is currently in use. There is no need to adjust any more diaphragms – either in transmitted or in incident light.

Automatic Light Adjustment

The light intensity is automatically set to the light-gathering power of the objectives. This means that the brightness of the specimen image remains constant when you switch to a different objective – and there is no danger of glare. And because every task has its own specific requirements, you can adjust the light intensity individually.

New: Transmitted Light Axis With Constant Color Intensity Control (CCIC)**

Too dark for viewing – too bright for your digital camera: in the past it was necessary to use a white balance every time the lamp voltage was changed. The new transmitted light axis works with a color-neutral brightness control which automatically maintains a constant color temperature. So you no longer need to use neutral density filters to compensate for changes in light intensity.

New Condensers for a New Level of Automation

Our fully automated condensers will meet the most demanding requirements. The motorized tops, which automatically swing in and out of the light path, are applicable from 1.25x to 100x. The motorized condenser turret accommodates up to four interference prisms and up to four phase rings as well as the brightfield and darkfield positions. We also offer an integrated, motorized polarizer for fully automatic interference contrast.

Clarity Wherever You Look

All the settings of the Leica DM4000 B/4500 B can be seen at a glance in the clearly laid out display. And the Leica DM5000 B/6000 B offers you never before realized control possibilities with the completely new touch-sensitive screen. You can control all the automated features of the microscope via the touch screen – there is no need to know anything about programming.

** Patented DE 101 32 360; pat. pend. for EP 02 100 723; Japan pat. pend. JP 2002 / 195868; US pat. pend. 10/173,101

Comfort

Our DigitalMicroscopes Adapt to You in Every Way

The new adaptable tube can be perfectly matched to your body size and posture. You can reach the focus knobs with your hands resting on the table. The new stage allows simultaneous focus and movement control. So whatever you are examining, you are completely relaxed – even if you sit at the microscope for hours at a time.

New Stages and Specimen Holders For Your Convenience

We have designed the new stages to satisfy the most demanding applications: scratch-resistant thanks to the ceramic coating and featuring telescopic stage drives with individually adjustable torque. To eliminate the risk of injury, we decided not to implement a rack for the y movement. The rotatable stages are suitable for one to two specimens and are available in a version for left-handed operation on request. Even more comfort is offered by the motorized stages of the Leica DM6000 B.

Variable Function Keys

You can assign any function you like to the ten new function keys. Six conveniently arranged buttons behind the focus dials provide you with easy and fast access to the functions you use most. There are an additional 4 function buttons for the Leica DM6000 B on the SmartMove unit. We had your comfort in mind.

Five New Viewing Tubes for Pin-Sharp Images

To match our new DigitalMicroscopes, we have devised a viewing tube series that will meet the highest requirements. Our new documentation tubes (which can be motorized on request) have three switching positions. Some of them are equipped with one or two optional camera outputs. The new comfort tube can be adjusted to suit your needs optimally. And of course, you will also find an ergonomometry tube with documentation port in our product range.

New 1.25x Scanning Objective

The new 1.25x panoramic objective is especially intended for biological sciences. In combination with our new transmitted light axis, it gives you excellent field depth and optimum illumination homogeneity for low magnification imaging.

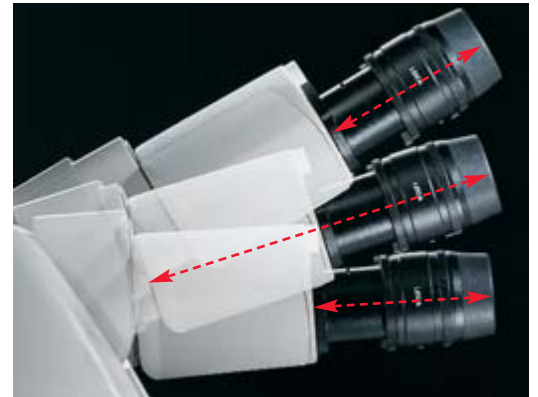

The viewing angle and height of the new AET22 adaptable tube can be individually adjusted to your sitting posture and body size. Plus you can vary the length of the eyepieces to suit the position of your arms..

Brilliance

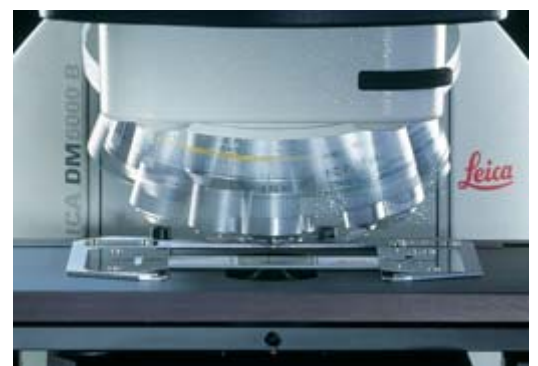

Together with the new condenser, our new transmitted light axis permits Koehler illumination from 1.25x - 100x. Furthermore, each time the objective is changed, the illumination manager makes the necessary adjustments to ensure optimum image impression.

Your Applications – Our Solutions

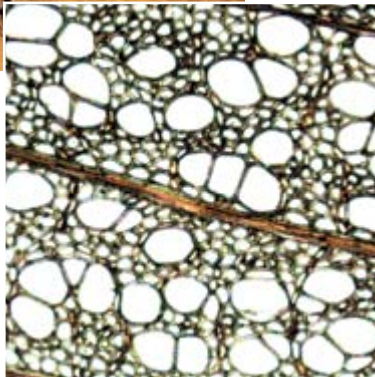
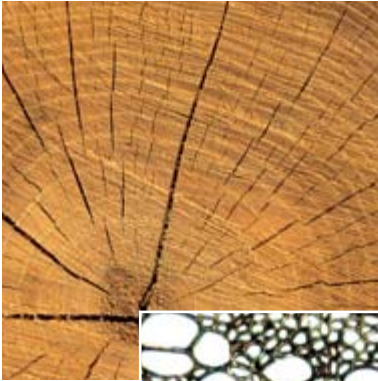

Cross section through tilia wood. Brightfield.

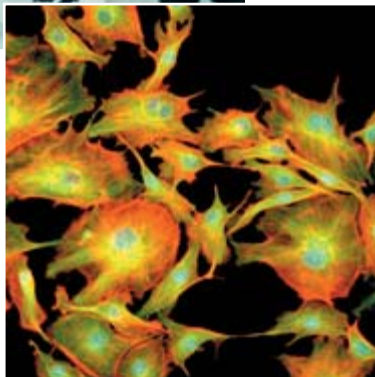

BPAE cells with mouse anti- α -tubulin, BODIPY^{FL} goat anti-mouse IgG, Texas Red[®]-X phalloidin, DAPI. Molecular Probes.

Transmitted Light

Brightfield

It has never been so easy to use a microscope: just put a specimen on the stage and focus! The Leica DigitalMicroscope recognizes the objective you have chosen, automatically sets the condenser top, accurately opens and closes the aperture and field diaphragms and adapts the light intensity. The automated color-neutral brightness control also filters red and orange components out of the light, giving you a constant impression of your specimen.

Phase Contrast

There is no further need to search and select phase contrast rings. The DM knows the right ring for the objective you have selected. Each objective has its own ring, saving you the nuisance of re-centering.

Interference Contrast

The Leica DM5000 B/DM6000 B is the first microscope to offer totally automated interference contrast. All the modules are fully motorized: analyzer, polarizer, condenser prisms and objective prisms. The Leica DM5000 B/DM6000 B also knows the right condenser and objective prisms for the objective you have chosen and moves them and the polarizer and analyzer automatically into the light path. The microscope stores the fine objective prism settings for each objective so that they can be reproduced whenever needed.

Darkfield and Polarization

Of course, all the other contrasting techniques implemented in the Leica DigitalMicroscope series, such as darkfield and polarization, are automated, too. Here again, the microscope knows all the necessary components.



Leica Design by Christophe Apothéoz

Fluorescence

New: FIM method and fluorescence booster

FIM: The world's first method that lets you adapt fluorescence illumination to your needs quickly and precisely. With the simple touch of a button, the Fluorescence Intensity Manager (FIM) reduces the light intensity in 5 fixed steps – guaranteeing absolute reproducibility. This can be used to effectively prevent specimens from fading prematurely. It also lets you store a separate FIM step for each fluorescence filter to obtain a constantly bright image of multiple-stained specimens. And if you need more light, simply switch on the new booster lens, which immediately directs more light to your sample if required.

5- and 8-position Filter Cube Changer

All stands for the new Leica DigitalMicroscopes can be equipped with a turret for up to five fluorescence filter cubes. The Leica DM5000 B/6000 B can also be supplied with an 8-position filter turret on request. Both filters take the same type of filter cube, allowing you to switch conveniently between different versions. When calling up filter cubes, you have the choice of switching between all blocks continuously or calling up individual filter cubes directly.

Integrated BG38 Filter

Manual insertion of a BG38 filter for certain fluorescence applications is no longer necessary. The function of this filter has been integrated on the fluorescence filter cubes.

Single Keystroke Contrast Switching – Easier Than Ever Before

The method of changing contrasting techniques is unique. One press of the innovative function keys and the microscope switches between brightfield, phase contrast, polarization, darkfield or fluorescence automatically. For the Leica DM5000 B/6000 B stands, we have even assigned all the interference contrast settings to a single key.

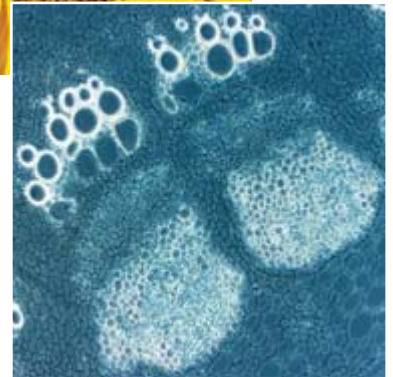

Cross section through the axis of a helianthus shoot, openly collateral bundles, phase contrast.

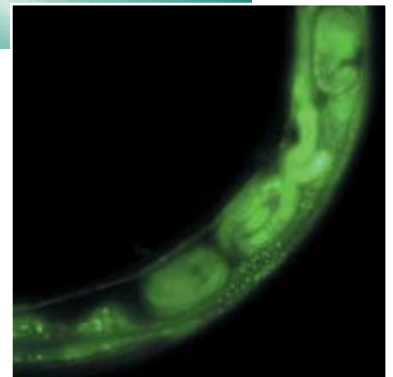

Transgenic *C. elegans* displaying GFP expression. Courtesy of Dr. M. Morcos, Heidelberg, Germany



Your System Solutions

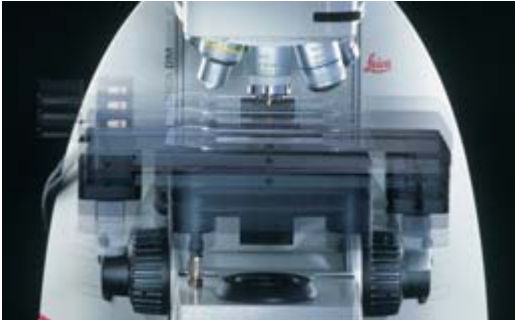

Our motorized stages in the Leica DM6000B function as an integral part of the complete system and can, of course, be controlled using our software programs.

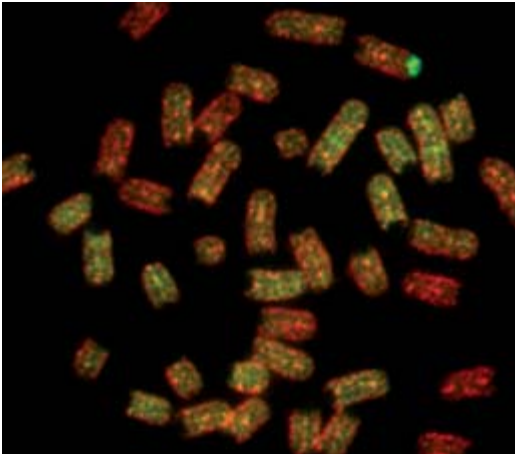

Metaphase-spread FISH – stained chromosomes
Photos: Dr. Yumiko Suto, Tokyo University
Courtesy of Dr Yumiko Suto,
Biological Sciences, University of Tokyo, Japan.



The Choice Is Yours. Now and in the Future.

To go with the new DigitalMicroscopes we offer you a totally new software concept which allows you to upgrade your system at any time. All future software and hardware components of Leica will be controlled from the same interface.

Individual Microscope Configuration and Control

The user interface is very easy and intuitive to use. Function keys, contrasting techniques and other microscope parameters are easily configured on the computer in accordance with your preferences or the needs of your working environment. Remote control of the microscope using the software is reliable and comfortable – particularly important in a routine environment.

Digital Cameras For Every Requirement

The new digital cameras from Leica offer the correct solution for every application. The standard FireWire interface provides a fast means of transferring images to PCs and Macintosh computers. The application areas range from color or black-and-white images for all medical and biological photography requirements, to long-term exposure photography for fluorescence microscopy at low light intensity. All digital cameras have variable resolution with live image mode; the image resolutions range from 1.3 to 12 megapixels at a color depth of up to 14 bits per color channel.

Leica
MICROSYSTEMS

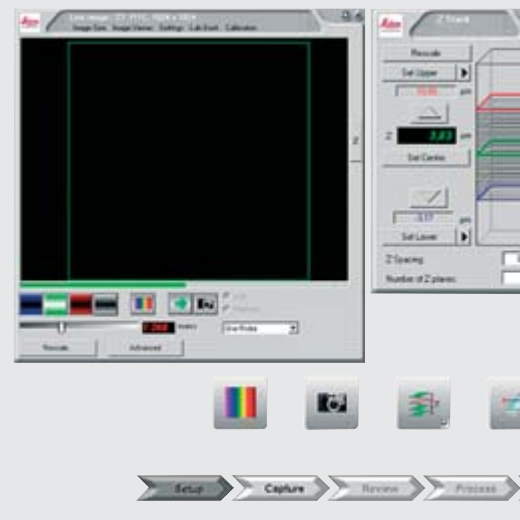

Perfect Image Archiving and Analysis

With the Leica IM image and data management software, you can document, edit and survey your microscopic images. Also, all automated microscope parameters can be stored with the images and reimported to the microscope if required for "reproducible microscopy." The FW4000 fluorescence image processing workstation offers a complete solution for capturing, editing and archiving fluorescence images, using a self-explanatory user interface designed in cooperation with users themselves. The Leica CW4000 cytogenetics program offers solutions for karyotyping, FISH (Fluorescence In-Situ Hybridization), MFISH (Multi-Colored FISH) and CGH (Comparative Genome Hybridization), etc.

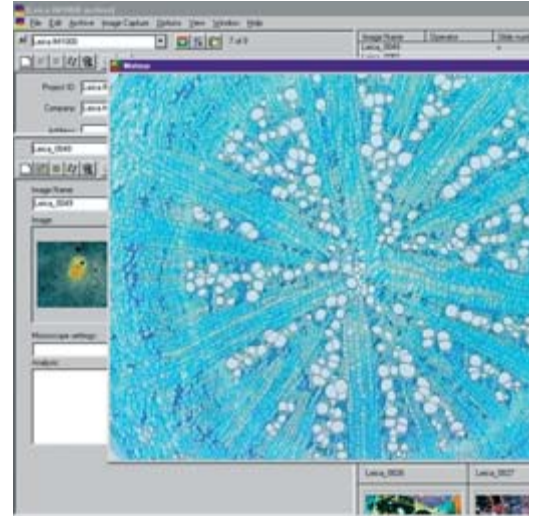

Integration



Our Product Line



Leica DM4000 B with fluorescence axis and Standard BT 25+ binocular tube.

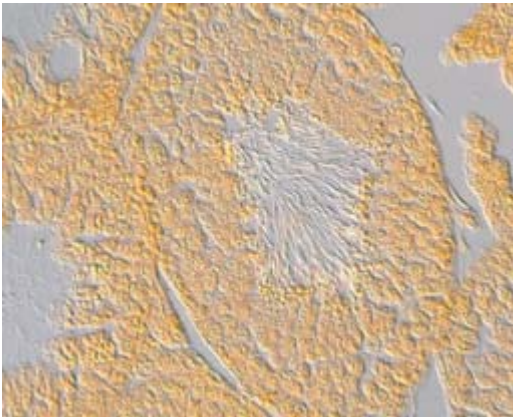

Differential interference contrast image – taken with a Leica DM4500 B.

Leica DM4000 B – The Ideal Entry-Level Microscope For High-End Routine Applications

Enjoy the convenience of a fully automated microscope for routine users at an attractive price. For the first time, the automation of your routine microscope allows you to repeat your examination at any time with perfect reproducibility. And the time savings will bring a smile.

The modular design of our microscopes allows you to customize the configuration of your microscope to meet your specific needs. The Leica DM4000 B is equipped with a transmitted-light axis and can be used with all common transmitted-light methods (brightfield, darkfield, phase contrast, polarization contrast – all fully automated*). A fluorescence axis can be ordered directly or can be retrofitted later at any time. It has a 5x filter disk for equipping it with fluorescence filter cubes, which you can select from our wide range of products. As you would expect from a routine microscope, the DM4000 B has a mechanical Z drive; the stage is also mechanically operated. The 6x objective turret is absolute encoded, so that the objective in use is detected immediately. All current setting values can be called up at a glance using the clearly designed status display.

Leica DM4500 B – The Routine Microscope For All Users who Use Interference Contrast

The Leica DM4500 B is specially designed for all routine users who work with differential interference contrast. It offers you all the possibilities of the Leica DM4000 B, and leaves the option of interference contrast up to you.

The Leica DM4500 B is equipped with a transmitted-light axis which, in addition to the methods which can be used with the DM4000 B (brightfield, darkfield, phase contrast, polarization contrast – all fully automated), supports a partially automated interference contrast. The interference contrast can be retrofitted, and works with mechanically inserted objective prisms. The status display indicates which prism you have to use. Like the DM4000 B, you can order a fluorescence axis directly or have one retrofitted, and it is equipped with a 5x filter turret. Also like the DM4000 B, the Z drive and the stage are mechanical. The objective turret of the Leica DM4500 B, which is also encoded, offers space for 7 objectives – one more than in the Leica DM4000 B.

* Differential interference contrast can be performed with microscopes of the DM4500 class or higher only. This contrast option cannot be retrofitted onto the Leica DM4000 B.

Leica DM5000 B – The Entry-Level Research-Class Microscope

The automation of the DM6000 B makes work easier, even – and particularly – for beginners or new users. The ability to reload and repeat settings at any time guarantees a previously unseen level of reproducibility for your experiments. The included DMControl software package allows undreamed-of possibilities for remote control of your microscope.

The standard built-in automatic transmitted-light axis of the Leica DM5000 B can be used with all common transmitted-light methods – including the world's first fully automated interference contrast. You can order a fluorescence axis directly with the unit or have one retrofitted later, and you can choose between a 5x or 8x* filter turret. The stand is equipped with a manual Z drive as well as a mechanical stage. The absolute encoded objective turret offers space for 7 objectives – enough to leave even infrequently used objectives attached to the microscope at all times. Particular comfort is offered by the touch-sensitive LeicaScreen, which provides an easy-to-understand menu structure that enables you to control all available motorized modules of the microscope.

Leica DM6000 B – The Research Microscope that Leaves Nothing To Be Desired

The automation of this microscope, every module of which is motorized, is brilliant. Together with our new digital cameras, which have been specially tuned to match the DM DigitalMicroscope series, as well as software products for image analysis and image archiving, you will receive a system that is custom-tailored for your work.

The automated transmitted-light axis of the Leica DM6000 B can be used with all common transmitted-light methods – including fully automated interference contrast. The stand is also equipped with a standard fluorescence axis, which optionally can be fitted with a 5x or 8x filter turret. The Z drive of the Leica DM6000 B is motorized, providing you with the conveniences of parfocality and saved focus levels. Additionally, the Leica DM6000 B features a motorized stage which functions as an integral part of the entire system. The objective turret offers space for 7 objectives, and is also motorized and absolute encoded. The LeicaScreen makes controlling all motorized components particularly easy. It is supported by the Leica "SmartMove" remote control unit.



Leica DM6000 B with MBDT motorized documentation tube and encoded magnification changer. The fluorescence axis is equipped with an 8x filter cube changer.

* If the fluorescence axis is retrofitted later, it cannot be equipped with an 8x filter turret. In this case, the fluorescence axis must be ordered with a 5x filter turret.

Technical Data

		Leica DM4000 B	Leica DM4500 B	Leica DM5000 B
Stand	Power supply	– Integrated in stand		– In CTR5000 electronics box
	Display	– Information display (3.7 x 7.7 cm)		– LeicaScreen (7.3 x 7.3 cm) with information and control panels
	Interfaces	– 1 x RS 232		– 1 x RS 232
Operation	Focus	– mechanical – 2-gear drive		– mechanical – 2-gear drive
	Objective turret	– absolute encoded		– absolute encoded
		– 6x M25 thread	– 7x M25 thread	– 7x M25 thread
	Stage			
		– mechanical – ceramic-coated – y-drive with cable control – telescopic stage drive with adjustable torque – 110° rotation – optional left-handed version available		– mechanical – ceramic-coated – y-drive with cable control – telescopic stage drive with adjustable torque – 110° rotation – optional left-handed version available
Control elements	– 6 freely programmable function buttons		– 6 freely programmable function buttons	
Transmitted-light axis	Illumination	– 12V 100W halogen lamp		– 12V 100W halogen lamp
	Automation	– Automatic illumination manager (brightness adjustment) – Automatic contrast manager (field and aperture diaphragm adjustment) – Constant Color Intensity Control (CCIC)		– Automatic illumination manager (brightness adjustment) – Automatic contrast manager (field and aperture diaphragm adjustment) – Constant Color Intensity Control (CCIC)
	Contrast techniques	– BF – PH – DF – POL		– BF – PH – DF – POL
			– ICT (partially automated)	– ICT (automated)
Fluorescence axis	Mot. filter turret	– 5-position		– 5-position – 8-position
	Illumination	– 100W halogen lamp – 50W halogen lamp		– 100W halogen lamp – 50W halogen lamp
	Automation	– Automatic illumination manager (FIM) (brightness adjustment) – Automatic contrast manager (field diaphragm adjustment) – Circular and rectangular field diaphragms for eyepiece or camera viewing		– Automatic illumination manager (FIM) (brightness adjustment) – Automatic contrast manager (field diaphragm adjustment) – Circular and rectangular field diaphragms for eyepiece or camera viewing
Condensers	Automation	– Mot. condenser top – Mot. condenser turret 7-position (optional) – Mot. polarizer (optional)		– Mot. condenser top – Mot. condenser turret 7-position (optional) – Mot. polarizer (optional)

Leica DM6000 B

- In CTR6000 electronics box
- LeicaScreen (7.3 x 7.3 cm) with information and control panels
- 1 x RS 232
- motorized
 - 5 electronic transmissions
 - including parfocality function
 - toggling between coarse and fine mode
 - storage of 2 z positions possible
- motorized
 - including dry and immersion mode
- 7x M25 thread
- motorized
 - with stepper motor
 - toggling between fast and precise modes
 - storage of up to 6 stage positions possible
- mechanical
 - ceramic-coated
 - y-drive with cable control
 - telescopic stage drive with adjustable torque
 - 110° rotation
 - optional left-handed version available
- 6 freely programmable function buttons
- SmartMove
 - Control elements for z (focus) movement
 - Control elements for x,y (stage) movement
 - 4 freely programmable function buttons
- 12V 100W halogen lamp
- Automatic illumination manager (brightness adjustment)
- Automatic contrast manager (field and aperture diaphragm adjustment)
- Constant Color Intensity Control (CCIC)
- BF
- PH
- DF
- POL
- ICT (automated)
- 5-position
- 8-position
- 100W halogen lamp
- 50W halogen lamp
- Automatic illumination manager (FIM) (brightness adjustment)
- Automatic contrast manager (field diaphragm adjustment)
- Circular and rectangular field diaphragms for eyepiece or camera viewing
- Mot. condenser top
- Mot. condenser turret 7-position (optional)
- Mot. polarizer (optional)

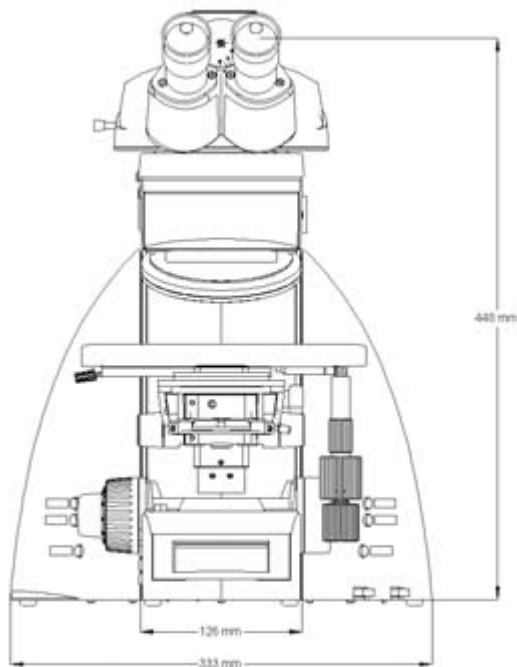
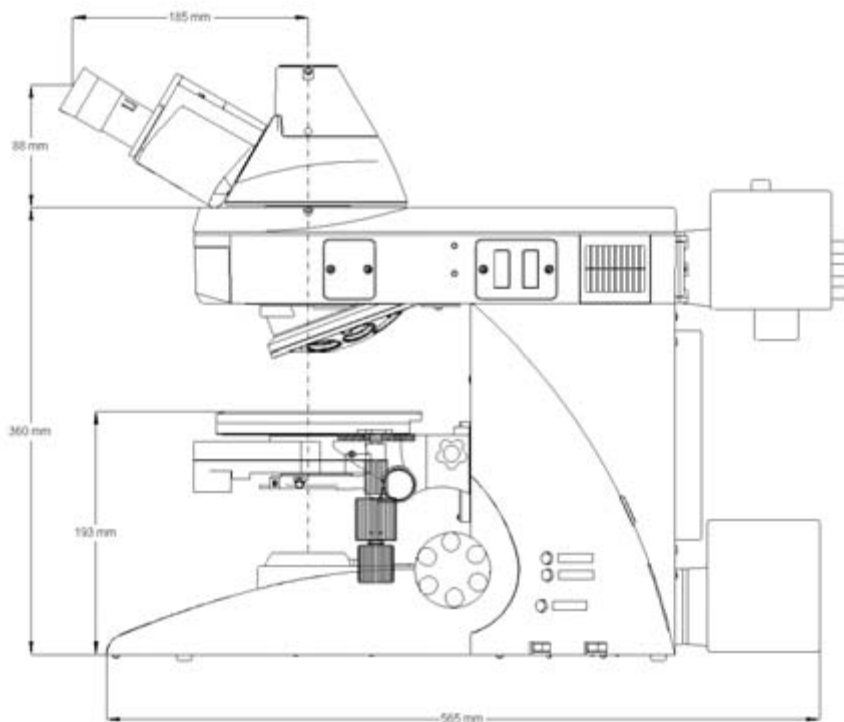

System Overview

Leica DM4000 B/DM4500 B DM5000 B/DM6000 B

Camera systems
Leica SCR camera system
Leica MPS30/60
see brochure

Interchangeable
magazine 24 x 36
Motor adapter
(24 x 36)
without optics
Camera objective
0,32x

Tube program L

11505148
AET 22
Advanced ergo tube incl.
tilting and extendable eyepieces

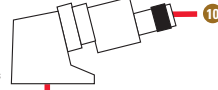

11505149
EDT 22 F 50/50
Ergo documentation tube
incl. tilting eyepieces

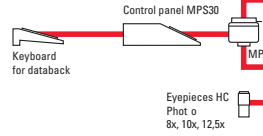
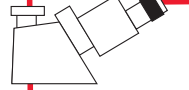

Control panel MPS30
Keyboard for databack
Eyepieces HC
Photo
8x, 10x, 12,5x

11505061
Ergomodule

11888095
Top cover

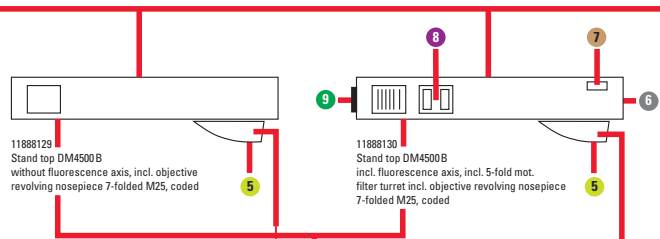
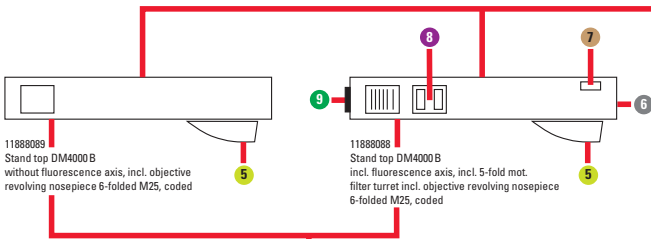

11888118
Cover
objective revolving nosepiece
incl. slot for
DIC prism sliders

DIC prisms in sliders
(for article numbers see
modular system brochure)

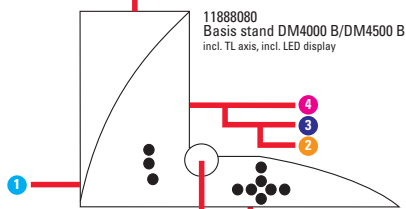

11888084
mech. Focus drive

11888098
Ground plate
without filter magazine

11888100
Ground plate incl. filter magazine
for 2 filters (D = 32 mm)
(for article numbers
see modular system brochure)

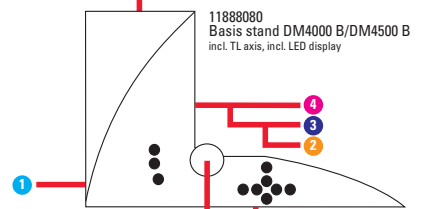

11888084
mech. Focus drive

11888098
Ground plate
without filter magazine

11888100
Ground plate incl. filter magazine
for 2 filters (D = 32 mm)
(for article numbers
see modular system brochure)

Leica DM4000 B

Leica DM4500 B

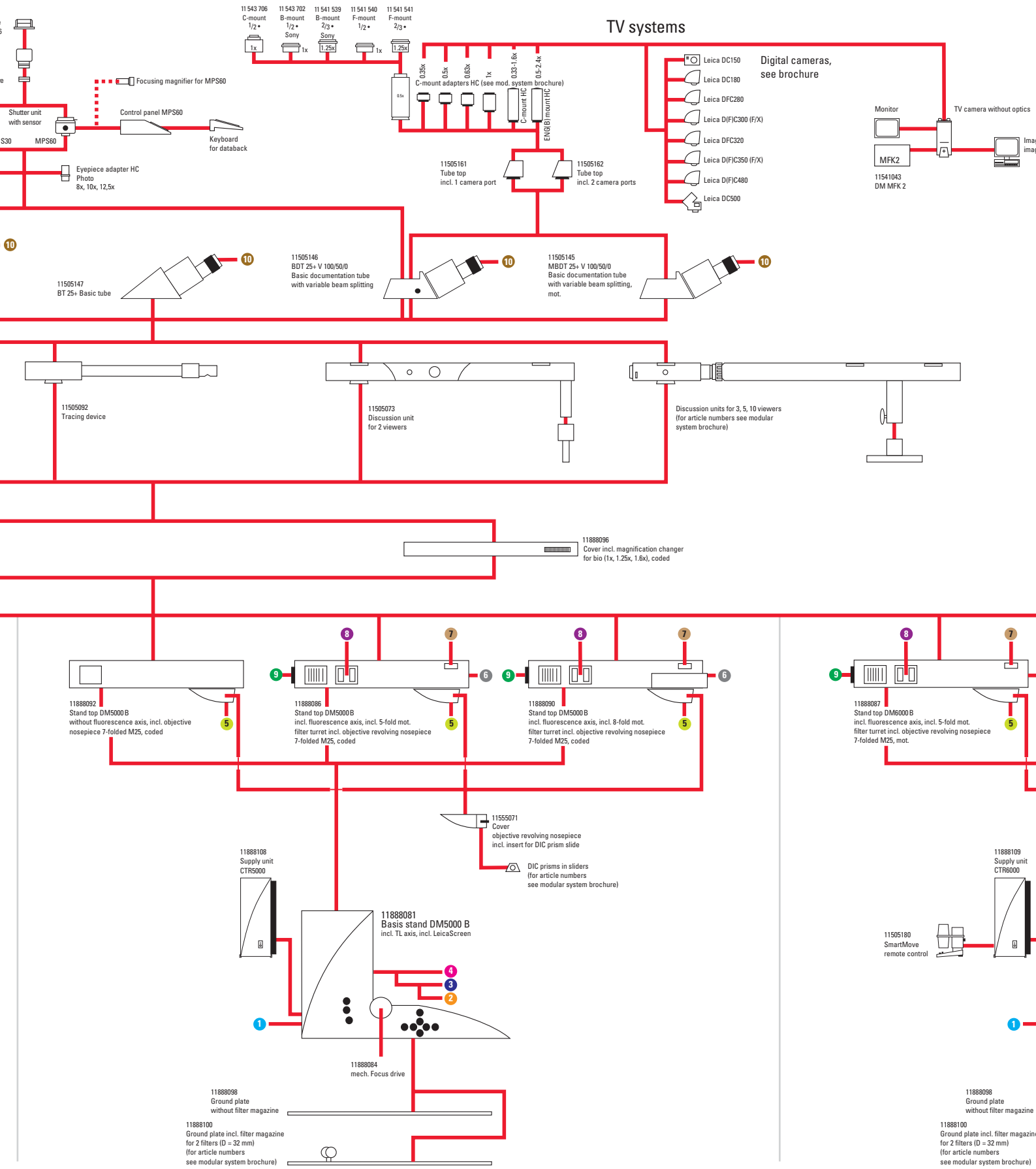

TV systems

Digital cameras, see brochure

Leica DM5000 B

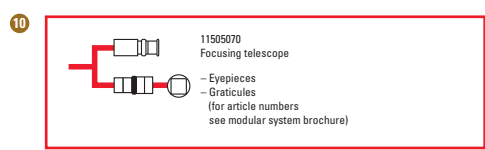
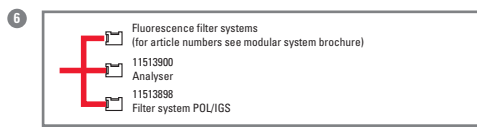
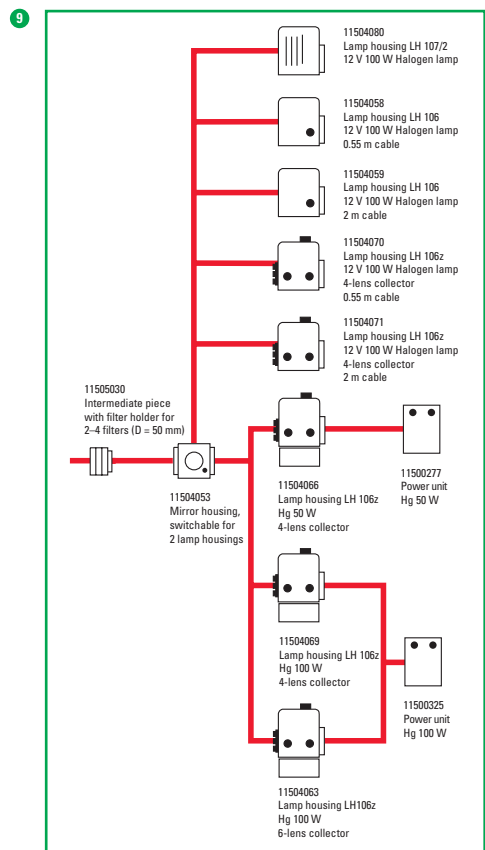
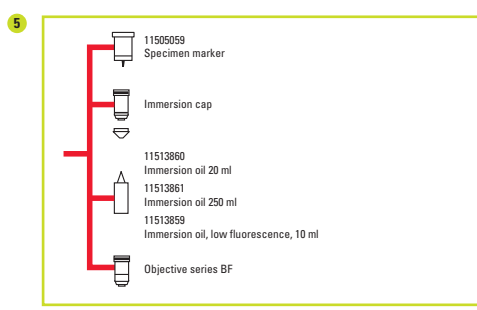
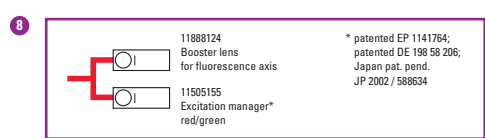
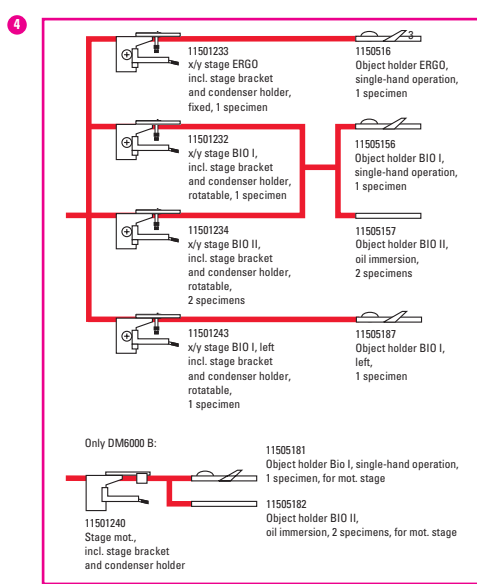
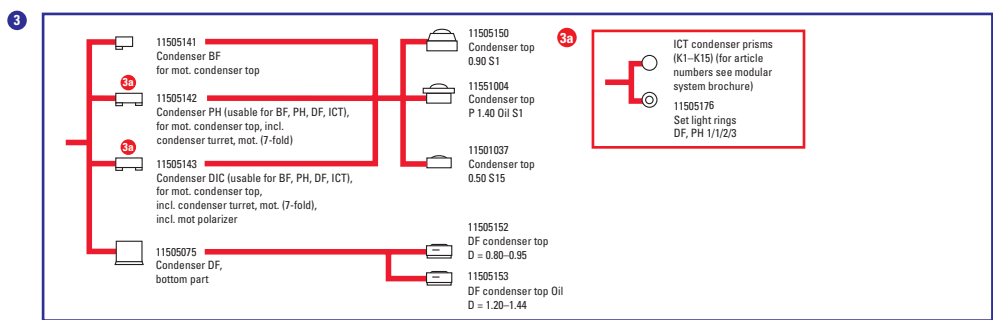
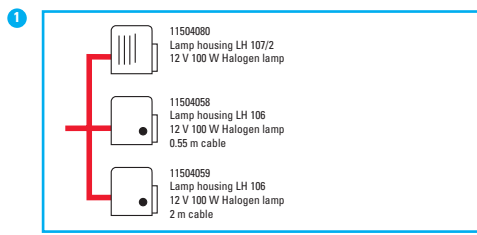
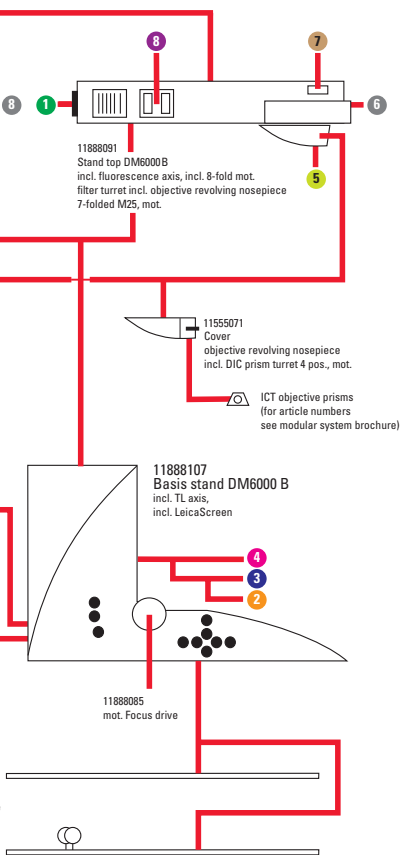



"Labeling molecules was as hard as writing on grains of dust with a pencil – until recently."

In my biochemistry course about 25 years ago I used to study molecules by the diagram of biochemical paths. Today, I can watch some of these old acquaintances at work and see them wandering from one living cell to the next and influencing cellular functions. Labeling molecules is now no longer a problem – using a research or confocal microscope of the Leica Fluorescence Microscopy range. Leica also offers me top-precision image analysis systems for their subsequent quantification.

Prof. Dr. H.J. Tanke, Leiden University Medical Center



Leica Microsystems – the brand for outstanding products

Leica Microsystems' mission is to be the world's first-choice provider of innovative solutions to our customers' needs for vision, measurement, lithography and analysis of microstructures.

Leica, the leading brand for microscopes and scientific instruments, developed from five brand names, all with a long tradition: Wild, Leitz, Reichert, Jung and Cambridge Instruments. Yet Leica symbolizes innovation as well as tradition.

The companies of the Leica Microsystems Group operate internationally in four business segments, where we rank with the market leaders.

● Microscopy Systems

Our expertise in microscopy is the basis for all our solutions for visualization, measurement and analysis of microstructures in life sciences and industry. With confocal laser technology and image analysis systems, we provide three-dimensional viewing facilities and offer new solutions for cytogenetics, pathology and materials sciences.

● Specimen Preparation

We provide comprehensive systems and services for clinical histo- and cytopathology applications, biomedical research and industrial quality assurance. Our product range includes instruments, systems and consumables for tissue infiltration and embedding, microtomes and cryostats as well as automated stainers and coverslippers.

● Medical Equipment

Innovative technologies in our surgical microscopes offer new therapeutic approaches in microsurgery.

● Semiconductor Equipment

Our automated, leading-edge measurement and inspection systems and our E-beam lithography systems make us the first choice supplier for semiconductor manufacturers all over the world.

Leica Microsystems – an international company with a strong network of customer services

Australia:	Gladesville	Tel. +61 2 9879 9700	Fax +61 2 9817 8358
Austria:	Vienna	Tel. +43 1 486 80 50 0	Fax +43 1 486 80 50 30
Canada:	Richmond Hill/Ontario	Tel. +1 905 762 2000	Fax +1 905 762 8937
Denmark:	Herlev	Tel. +45 4454 0101	Fax +45 4454 0111
France:	Rueil-Malmaison	Tel. +33 1 473 285 85	Fax +33 1 473 285 86
Germany:	Bensheim	Tel. +49 6251 136 0	Fax +49 6251 136 155
Italy:	Milan	Tel. +39 0257 486.1	Fax +39 0257 40 3273
Japan:	Tokyo	Tel. +81 3 5435 9600	Fax +81 3 5435 9615
Korea:	Seoul	Tel. +82 2 514 65 43	Fax +82 2 514 65 48
Netherlands:	Rijswijk	Tel. +31 70 4132 100	Fax +31 70 4132 109
People's Rep. of China:	Hong Kong	Tel. +852 2564 6699	Fax +852 2564 4163
Portugal:	Lisbon	Tel. +351 21 388 9112	Fax +351 21 385 4668
Singapore		Tel. +65 6779 7823	Fax +65 6773 0628
Spain:	Barcelona	Tel. +34 93 494 95 30	Fax +34 93 494 95 32
Sweden:	Sollentuna	Tel. +46 8 625 45 45	Fax +46 8 625 45 10
Switzerland:	Glattbrugg	Tel. +41 1 809 34 34	Fax +41 1 809 34 44
United Kingdom:	Milton Keynes	Tel. +44 1908 246 246	Fax +44 1908 609 992
USA:	Bannockburn/Illinois	Tel. +1 847 405 0123	Fax +1 847 405 0164

and representatives of Leica Microsystems
in more than 100 countries.

 www.simply-microscopy.com

LEICA
MICROSYSTEMS