



2026 Product Catalog

We make the invisible visible helping manufacturers, researchers, and educators get the most out of their materials

Our Trusted Partners



Office (408) 436-6336

Fax (408) 436-6343

orders@jhtechnologies.com

- 38 years delivering microscopy and metrology solutions for materials science, QA/QC, and manufacturing.
- Advanced instrumentation and analytical services to identify defects, optimize processes, and validate performance.
- Hands-on expertise ensures practical guidance and reliable results.

BUEHLER

SENSOFAR

Mitutoyo

Leica
MICROSYSTEMS

XAVIS

COXEM
KOSDAQ
LISTED COMPANY

CIQTEK

BRUKER

JH TECHNOLOGIES™
Making the Invisible Visible

OXFORD
INSTRUMENTS

CSI Concept Scientific Instruments
Atomic Force Microscopes

VT VacTradeUK

NAVITAR

tousimis



Four Demonstration Centers and Our Analytical Lab



Fremont, CA Showroom & Analytical Lab

- Applications engineers
- Imaging support
- Analytical services
- Over 100 years of combined experience
- \$2 million of demo inventory
- Stocking warehouse

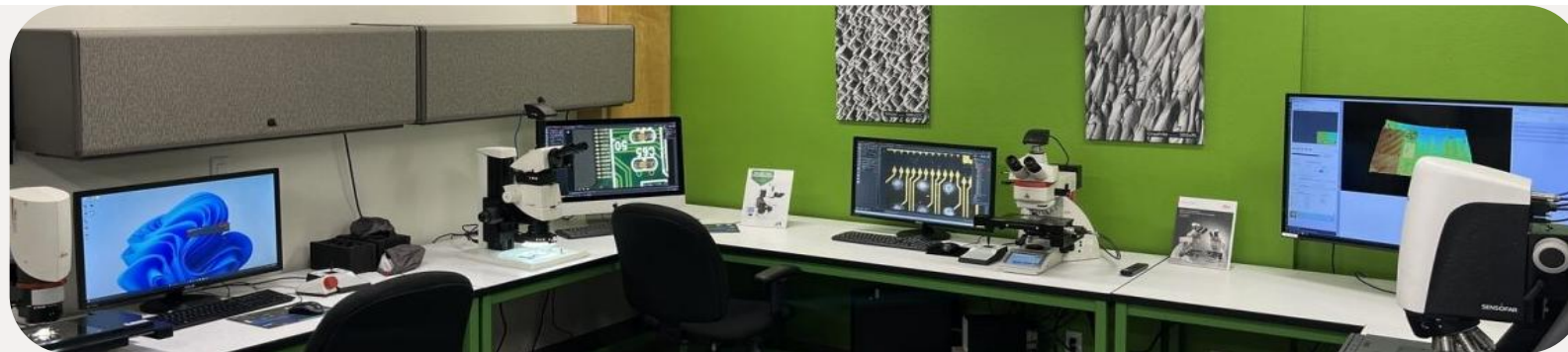

Southern California Showroom

18025 Sky Park Circle, Suite M
Irvine, CA 92614



Pacific Northwest Showroom

7969 SW Cirrus Dr. Bldg 22
Beaverton, OR 97007

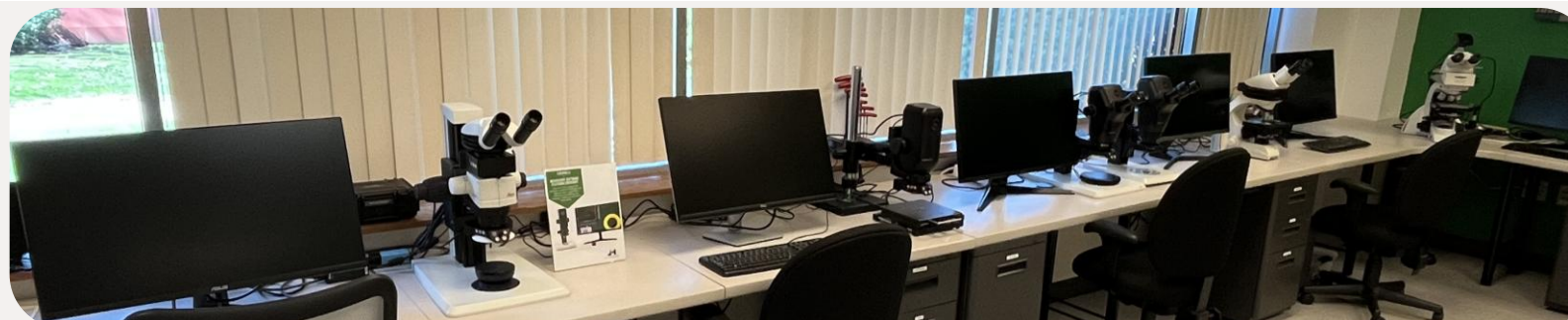

New England Showroom

11 Trafalgar Sq. Ste 103
Nashua, NH 03063

Table of Contents

05



Lab Services

06



Hands-On Support

07



Warranty & Maintenance Services

08



Microscopes

25

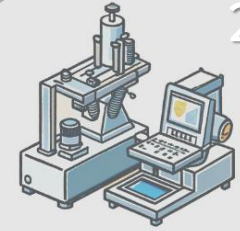

Metallography Equipment

35



Metrology

37



Surface Characterization

41



Electron Microscopy & Sample Prep

48



X-Ray Imaging

51



Cameras, Lenses, Software & Imaging

58



Optical Accessories

59



Optical Resources

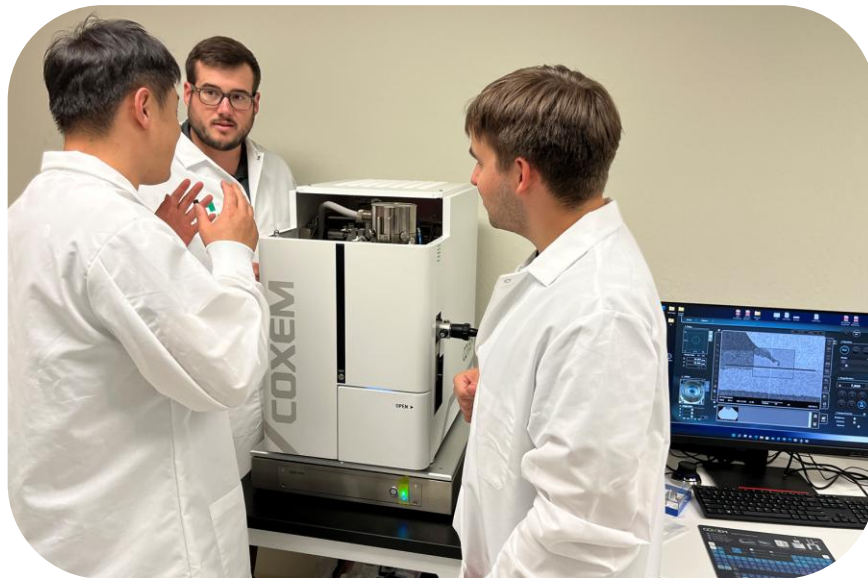









Services Offered:

- Failure Analysis
- Materials Characterization
- Sample Preparation
- Quality Validation



Applications

-  Microtechnology
-  Education
-  Medical Devices
-  Forensics
-  Semiconductor
-  Material Science
-  Metallography
-  Sample Preparation for Electron Microscopy

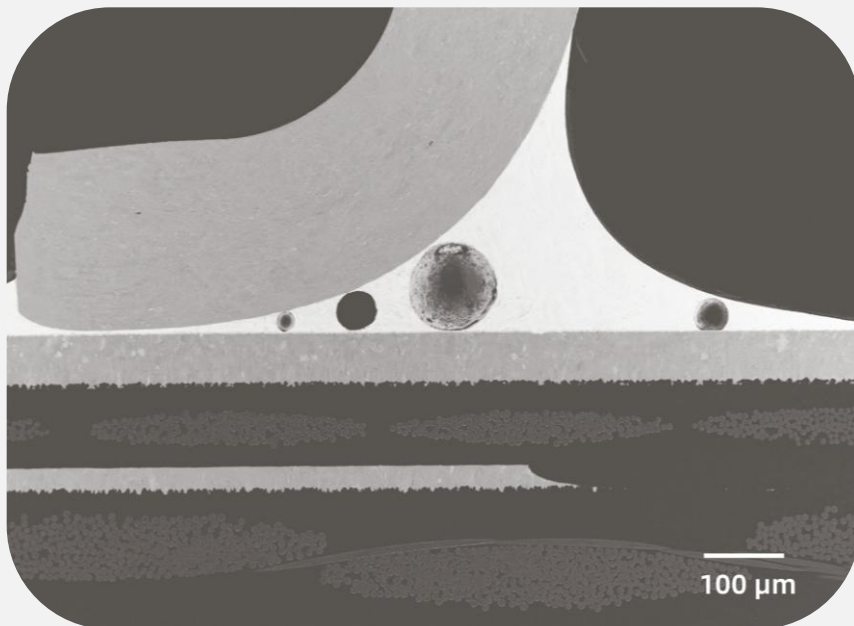

Complete Workflow Solutions

- Sectioning & Polishing
- Sample Prep for Electron Microscopy
- Electron, Optical, & X-Ray Imaging /Analysis
- Metrology/Surface Profiling
- Hardness testing
- Data Output

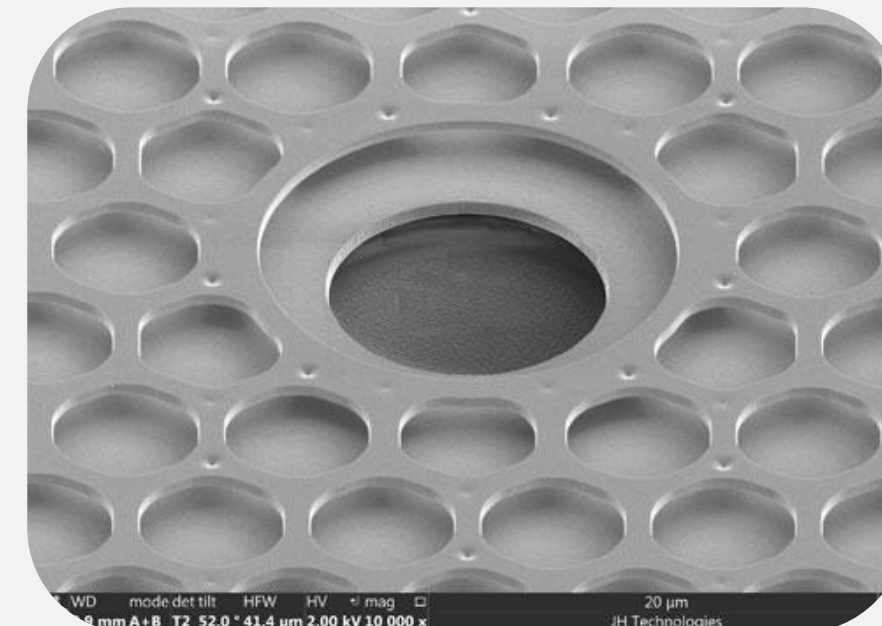

Featured Equipment:

- Metrology
- Metallography Sample Prep
- EM Sample Prep
- SEM 's
- Hardness Tester's
- Imaging /Analysis



Application-Driven Solutions

We take the time to understand your challenges and recommend the right microscopy and metrology solutions for your specific application—whether it's failure analysis, quality control, R&D, or production.



Integration & Training

From installation to workflow integration, we ensure your system is optimized, with comprehensive training to get your team up and running quickly.



We Care About Our Community

Community Service Program | Supporting K-12 Education

We believe in investing in the future of science. Through our iFuSE program, customers can donate or trade in used microscopes. We refurbish these systems and provide them to active STEM programs—bringing hands-on scientific exploration into the classroom.

Warranty and Maintenance Services

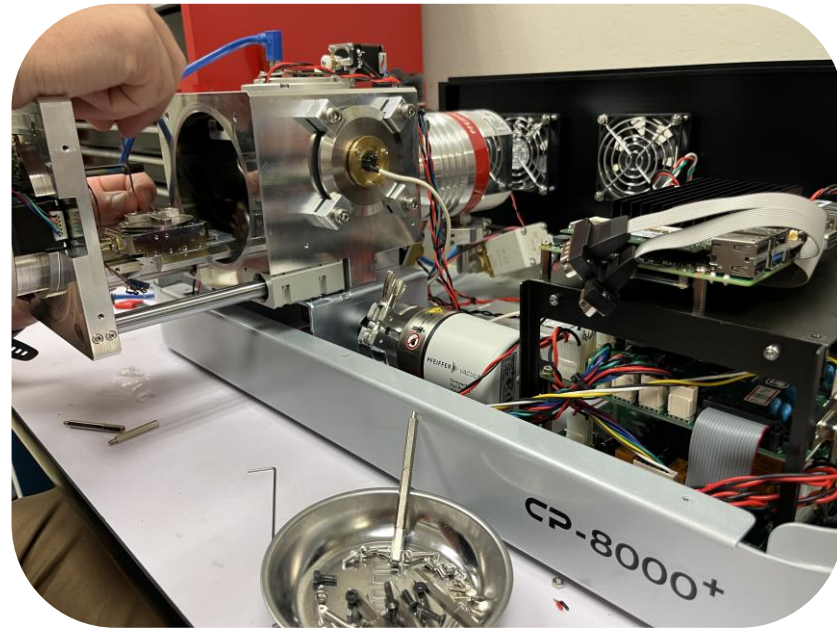

Preventative Maintenance

Regular inspections, calibrations, and tune-ups help extend the lifespan of your instruments, minimize downtime, and ensure optimal imaging quality.



Products We Service & Repair

Buehler, Bruker, Ciqtek, COXEM, Leica, Navitar, Oxford, Olympus, Nikon, Semprex, Sensofar, Xavis

Call for other manufacturers



Extended Warranty

We offer extended warranties on most brands, providing:

- Longer coverage for peace of mind.
- Expert repairs using certified parts.
- Minimized downtime with priority service.
- Optimized performance through regular maintenance.

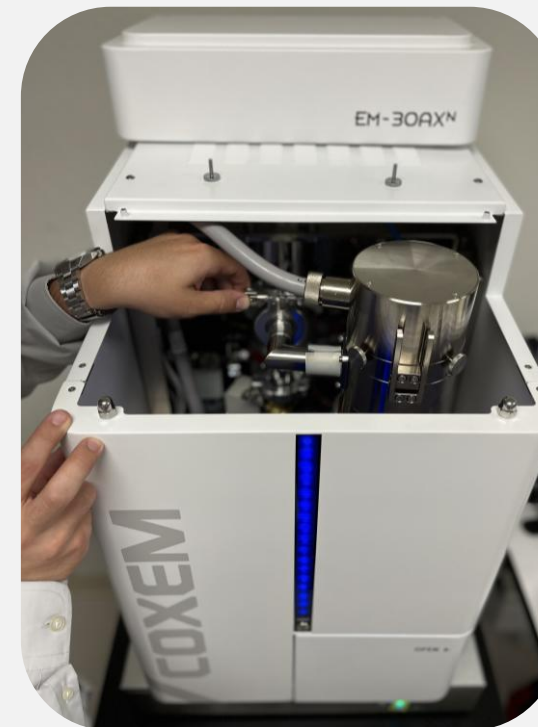

User Training/Process Development:

- Microscope Hardware & Software
- SEM Hardware & Software
- X-Ray Hardware & Software
- Sample Preparation
- Process Development



A Series

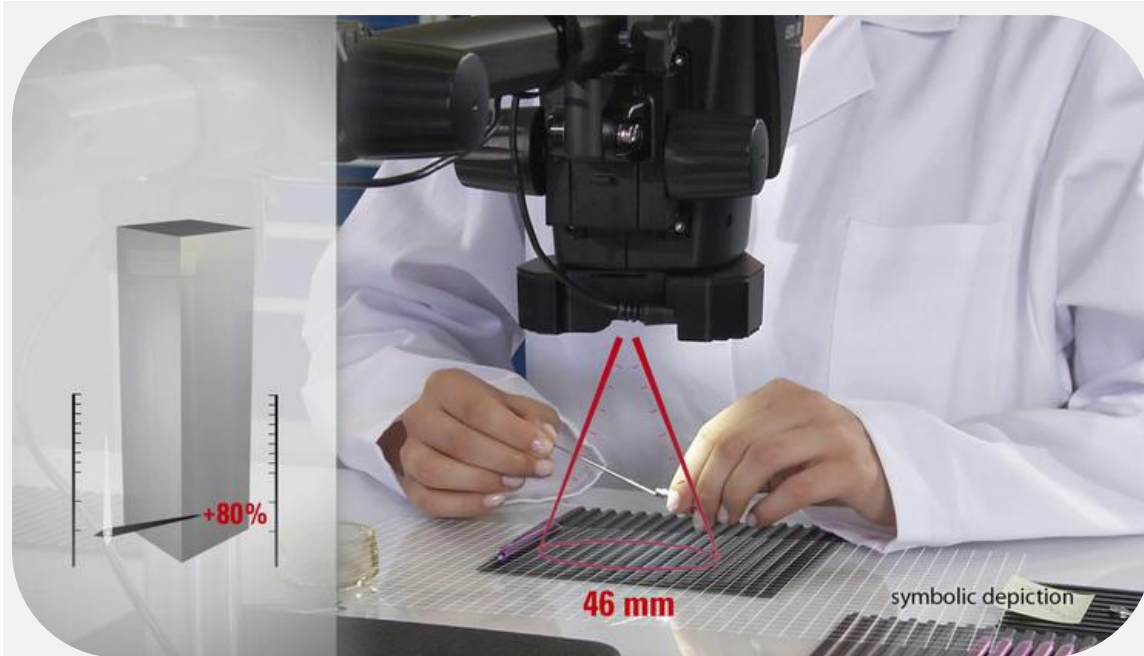

Increase your efficiency

For fast, comfortable and convenient work in production, assembly and rework.



Flexibility & Large Area Inspection

The table clamp allows maximum freedom of movement while requiring minimum table space. Ideal for handling large samples.

Ivesta 3 Series



Results you can rely on

Ensure consistent visual inspection according to standard procedures reducing the risk of human errors.



Facilitate inspection and measurement

Reproduce zoom settings through click-stops. Magnification settings are automatically saved along with the image data, using encoded zoom.

M 50/60/80/125 Series



Accuracy for repetitive tasks

Create traceable measurement procedures for repetitive jobs using the predefined zoom steps of the M50 or the click stops of the M60, M80. or M125

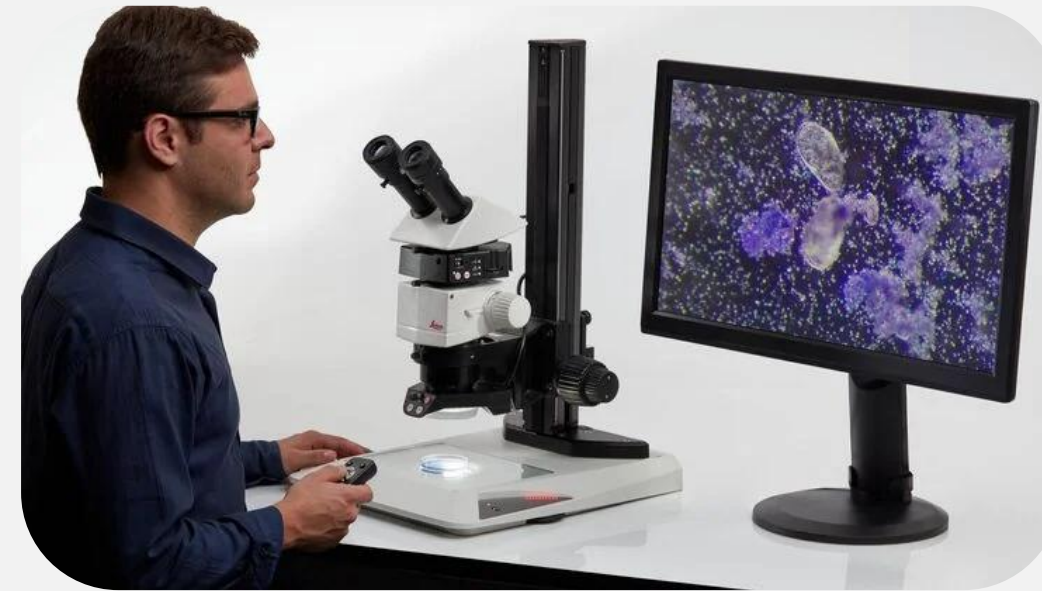

High flexibility with a modular concept

Customize the microscope to suit your needs with a large range of ergonomic accessories and illumination options



Working efficiently with Ergo accessories

Increase your productivity with an entirely ergonomic microscope for maximum comfort



Customizable for any application

Whether your work requires a variety of illumination techniques, different objectives, or a larger stand, let us help you choose the best solution for your application

M 165/205 Series



Tailored solutions – for those who demand more

Automated solutions designed to increase throughput with motorized stages, focus, and reproducible illumination



High flexibility with a modular concept

Customize the microscope to suit your needs with a large range of ergonomic accessories and illumination options



Easily acquire calibrated images

For accurate results and consistent documentation

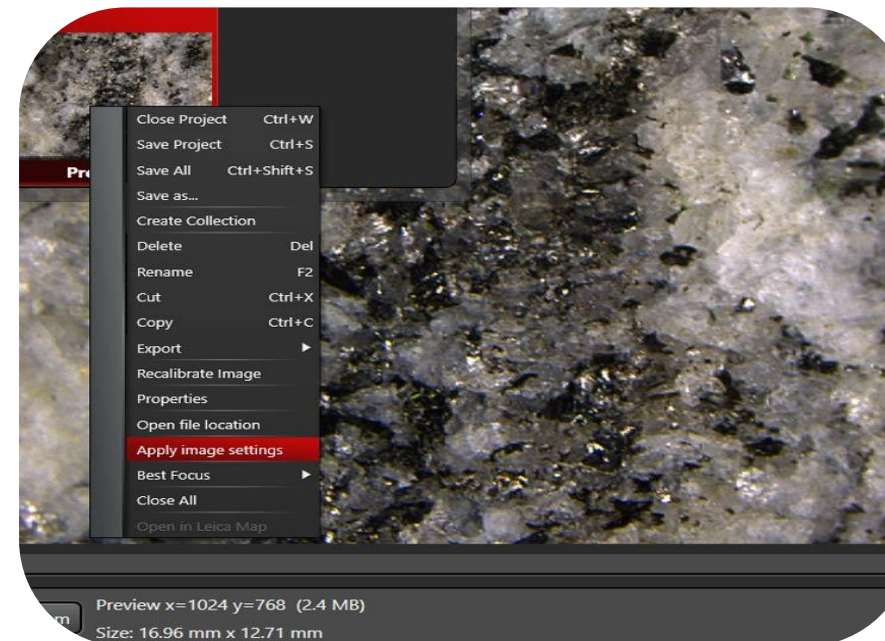

Easily recall settings at any time

- Fully encoded systems for repeatability
- Simple, easy to use software to setup automated processes

- Research M 165/205 Series

- Routine M80, Ivesta Series

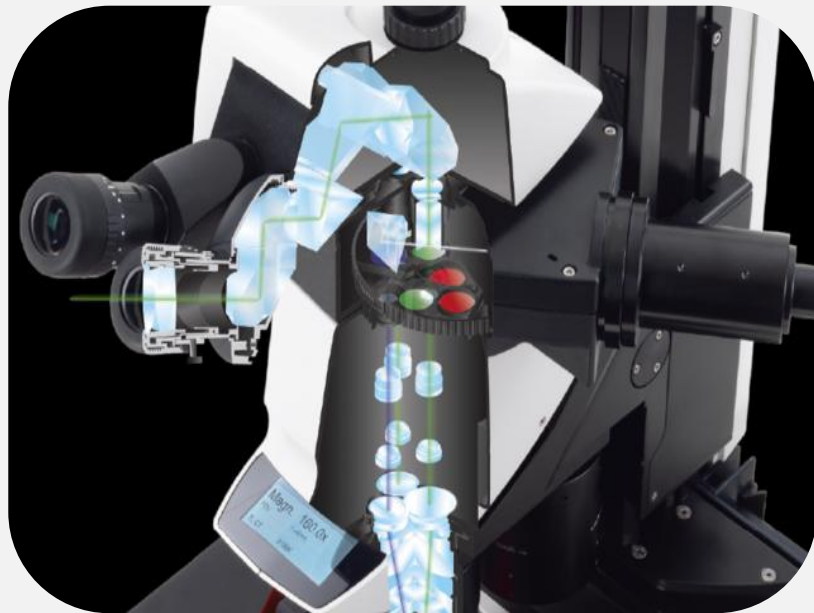

Discover the automated world of research

- Leica M205 FA: fully motorized fluorescence stereo microscope
- Revolutionizes fluorescence microscopy research
- Advanced automation capabilities



Bright fluorescence signals

- Separated yet synchronized beam paths
- Dedicated paths: one for excitation light, two for observation
- Evenly illuminated field of view at any zoom position



Finest details in 3D

- FusionOptics technology overcomes optical limitations
- Combines high resolution with excellent depth of field (DOF)
- Delivers superior image brightness for better 3D orientation



Fluorescence Routine Instrument

- LED light sources for basic instruments and routine applications
- Wide variety of configurations and wavelengths available
- Cost-effective solution for standard fluorescence needs

Cleanliness, Materials Science, Semiconductors

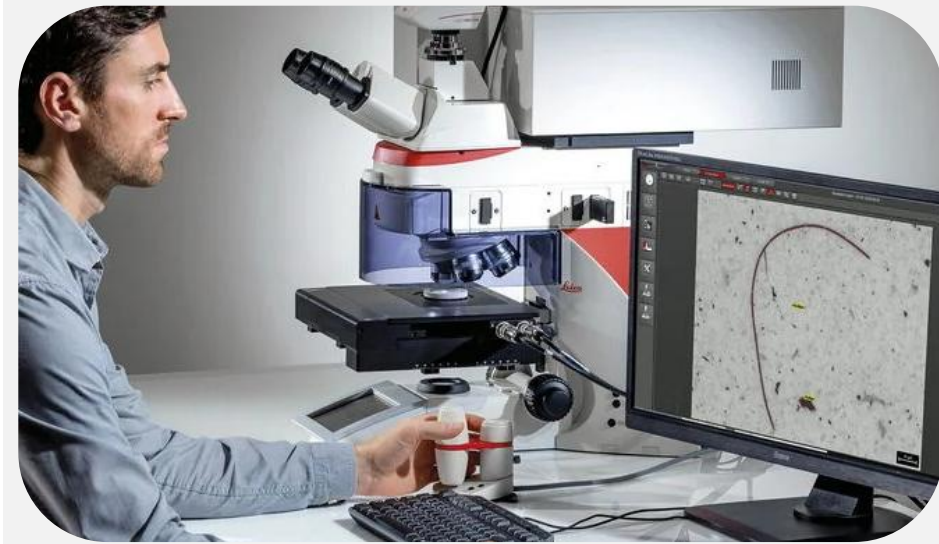

Cleanliness Analysis of Components

- Get particle composition and structure data simultaneously
- Make confident decisions faster during analysis



Upright microscopes for inspection and materials analysis

- Inspect and document results efficiently
- Customizable with LED illumination and ergonomic accessories

Semiconductor Inspection Systems

Visualize Structures and Defects

- Detect, analyze, and measure scratches, contamination, and various features
- Choose from multiple illumination options: brightfield, darkfield, polarization, DIC, fluorescence, and infrared
- Enhance resolution with ultraviolet light

Quick Defect Detection

- Reveal macro defects using optional 0.7x Macro objective
- 36mm field of view enables fast orientation and efficient screening
- Save time with rapid sample assessment





High-performance optics

- Superior image resolution and contrast using incident light, brightfield, polarization, and fluorescence
- Handles large samples efficiently
- Saves time during serial inspection and high-volume testing



Six contrast methods in one system

- Switch between samples 4× faster
- Accommodate samples weighing up to 30 kg
- Utilize UC-3D Illumination technology
- Achieve top resolution from any angle for more accurate inspection results



What makes an inverted compound microscope different?

An inverted compound microscope has its objective lenses below the sample and the light source above. That setup is the opposite of a standard upright microscope.



Comparison Microscopes

- Detect and identify the slightest differences in forensic evidence
- Examine bullets, cartridge cases, tool marks, and documents with precision
- Ensure accurate, reproducible results for reliable conclusions



Flexibility with precision and reliability

- Adaptable with specialized object mountings:
 - Rotary stages
 - Large object stages
 - Tilting stages
 - Bullet holders
 - Various custom mounts
- Designed for versatility without compromising accuracy



Forensic Medicine

- Supports multidisciplinary applications: biology, pathology, anthropology, toxicology, and DNA analysis
- Features tailored microscopes, cameras, and software for effective lab work
- Offers versatile optics, illumination options, and specialized forensic software



Explore in a flexible way

- Ideal solution for failure-analysis and R&D applications
- Single versatile platform for multiple research need



Investigate your samples with ease

- Versatile digital microscope for comprehensive sample investigations
- Features convenient operation to maintain focus on work
- Ensures reliable results with reproducible imaging conditions

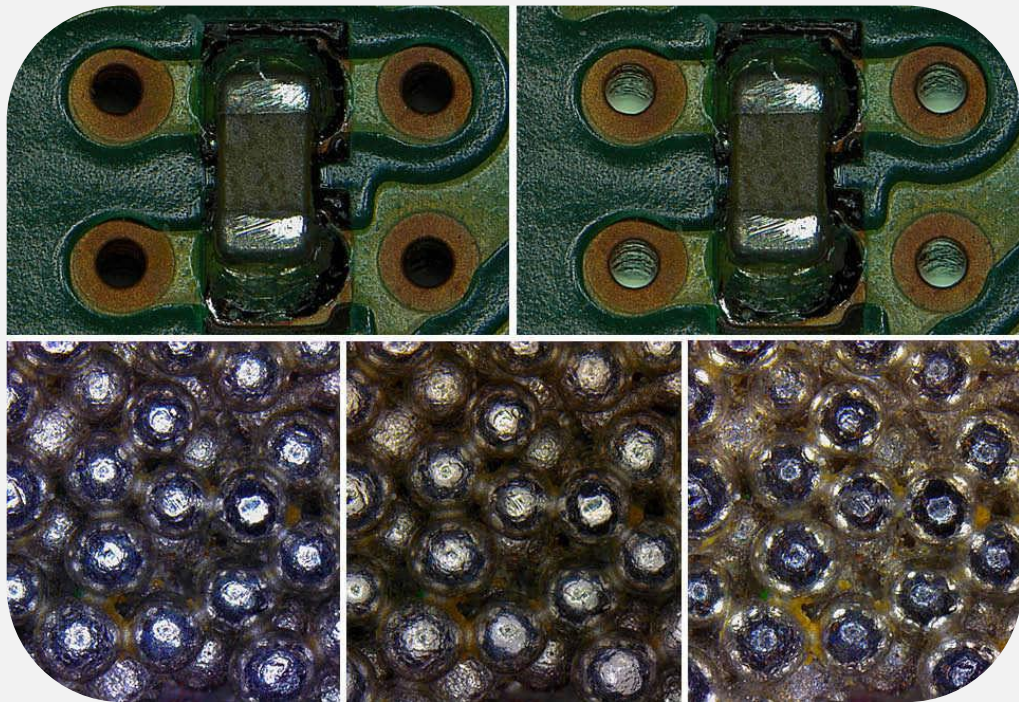

Reveal more details by combining options for illumination and contrasting in various ways.

- Ring light illumination (RL): View textured surfaces using one or all four segments
- Coaxial illumination (CXI): Visualize flat, reflective samples
- Transmitted light illumination (BLI): Explore holes and transparent materials
- Reduce glare on reflective samples with diffuser adapter or polarizer



Streamline your inspection process

The advantage of optimized inspection and adaptability to your needs combined in a single system.

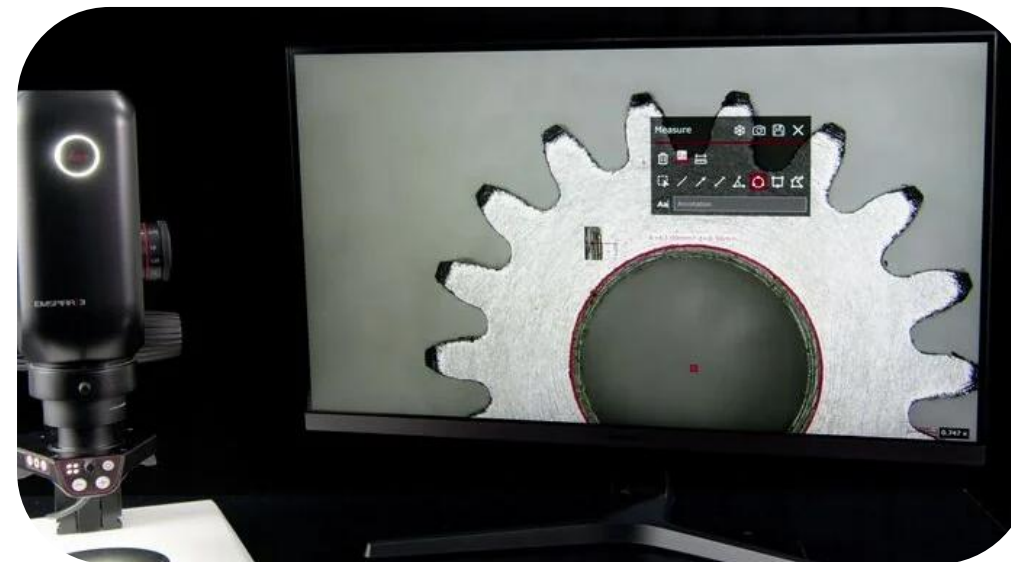

A flexible solution you can rely on

Flexibility to inspect and document according to your needs, access your data when you need it and work in industrial environments.



Get easy access to images

Create high contrast images and videos, reducing training and supervision time.



Measure and annotate directly without a PC

In stand-alone mode, you can measure multiple regions on the sample in the live image and save the results with it.



Compound Microscopes

- Precision optics with modern technology
- Integrated wireless camera for seamless documentation and viewing
- Exceptional clarity and ease of use
- Ideal for educational and routine laboratory applications



Dissecting Microscopes

A key instrument for your laboratory or classroom

- Essential instrument for laboratory or classroom settings
- Proper selection ensures long-lasting, satisfactory use
- Designed for extended dissection sessions by students and researchers



Wireless Classroom

- Digital Imaging Technology increases learning time and student engagement
- Interactive learning solutions include microscopes, cameras, and software
- Comprehensive ecosystem to enhance educational outcomes



Student-friendly

Supports a Student Friendly Classroom Environment - Binocular, fluorescence-capable educational microscope for life science courses



AgTreat™

All touchpoints treated to prevent bacteria spreading from student to student



The EZLite™ LED Illumination

One of the teacher-friendly features, provides cool white light with a life-time of over 20 years average use.



Inverted microscope supports your specific work routine

The DMi1 camera version is an all-in-one solution for image capturing and cell culture documentation. The 12 mp camera transforms your microscope into a stand-alone digital imaging station with no need for a PC



Educational stereo microscopes

The integrated 5-megapixel cameras can live-stream HD images to students' smartphones or tablets.



EZStore™ design

EZStore™ design with Handle and Cord Wrap allows easy carrying, easy lifting and easy cord storage

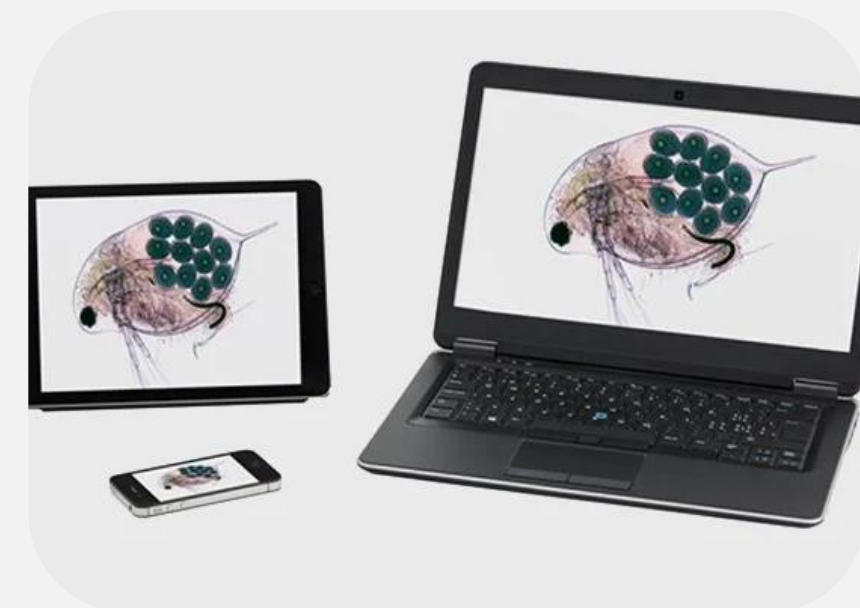

Camera access for multiple students simultaneously

Connect multiple smartphones or tablets and quickly access high-resolution images or videos fast directly onto your device through the camera's Wi-Fi stream.



Greenough Stereo Microscopes

You can optimize your visual inspection and rework while achieving reliable, consistent results with stereo microscopes.



Cameras

These 5-megapixel cameras can live-stream HD images to students' smartphones or tablets. Students can connect either through its own internal Wi-Fi signal or through the facilities network.



Leica AirLab App for easy learning and sharing

Capture, measure, annotate and archive microscope images with a mobile device.



Interactive Classroom with AirLab

Work with live image thumbnail overviews of all connected microscopes, share up to four images in class.

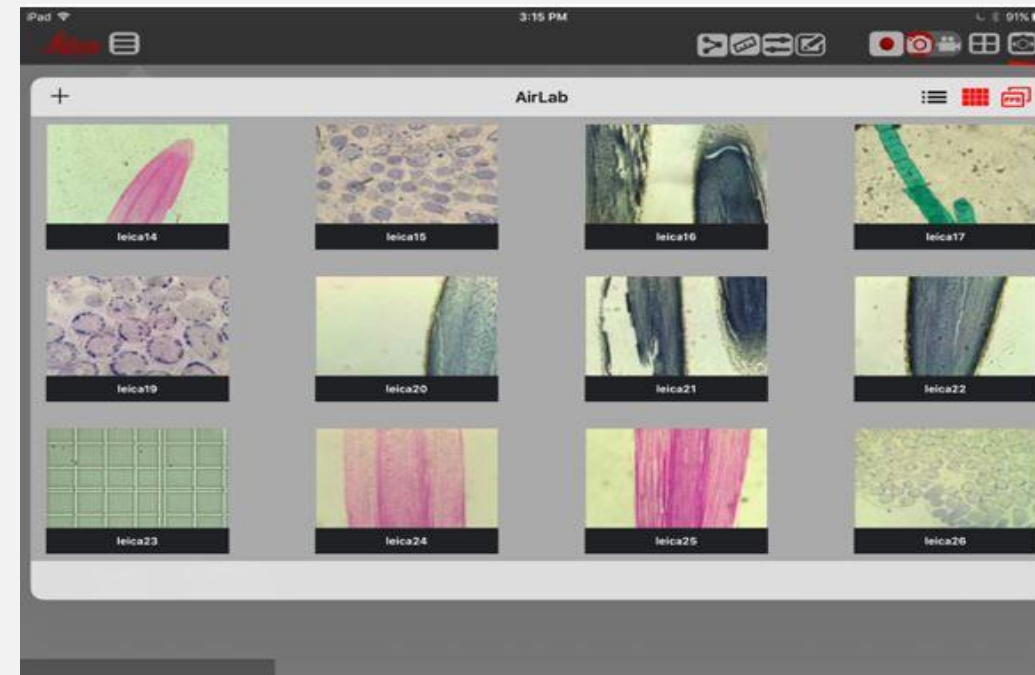

Live thumbnail overview AirLab

Overview all connected microscopes in class with a full-screen thumbnail overview.

Ring Lights

- Durability (25,000 to 50,000 hours, depending on the model)
- A natural color temperature
- Low power consumption (compared to halogen lamps)
- The illuminator can have a very compact design
- Usually operated without a fan (no noise)



Incident Lights

Bright incident contrast

Integrated 4-point LED top light – ensures a homogeneous and bright incident illumination.



Diffuse/Polarized

Light characteristic
36 high-output LEDs produce bright, uniform light.



UV/Fluorescent

High-performance fluorescence imaging enhanced by DIC, phase contrast, and polarization techniques.





Diffuse Ring Light

Spotlight illuminators are very useful for all kind of applications, where different contrast for reflected light is important.



Backlight

You benefit from bright, crisp images with distinct margins, injected directly into the microscope eyepieces.



Incident Light

With its flexible two-armed gooseneck and integrated LED spotlights, makes it easier for you to adjust the contrast for incident light.



Diffuse Dome Light

Produces a uniform light by means of the dome shape. The mechanically flexible design with silicone rubber eases your access to the specimen.



7- way LED illumination

Provides incident, oblique and transmitted light for high quality illumination and contrast of any application.



Stereo Microscope Fluorescence Adapter

Allows you to easily add powerful fluorescent illumination to your Leica EZ4 or S9 Series Microscope



Standard Bright Field White Light LED

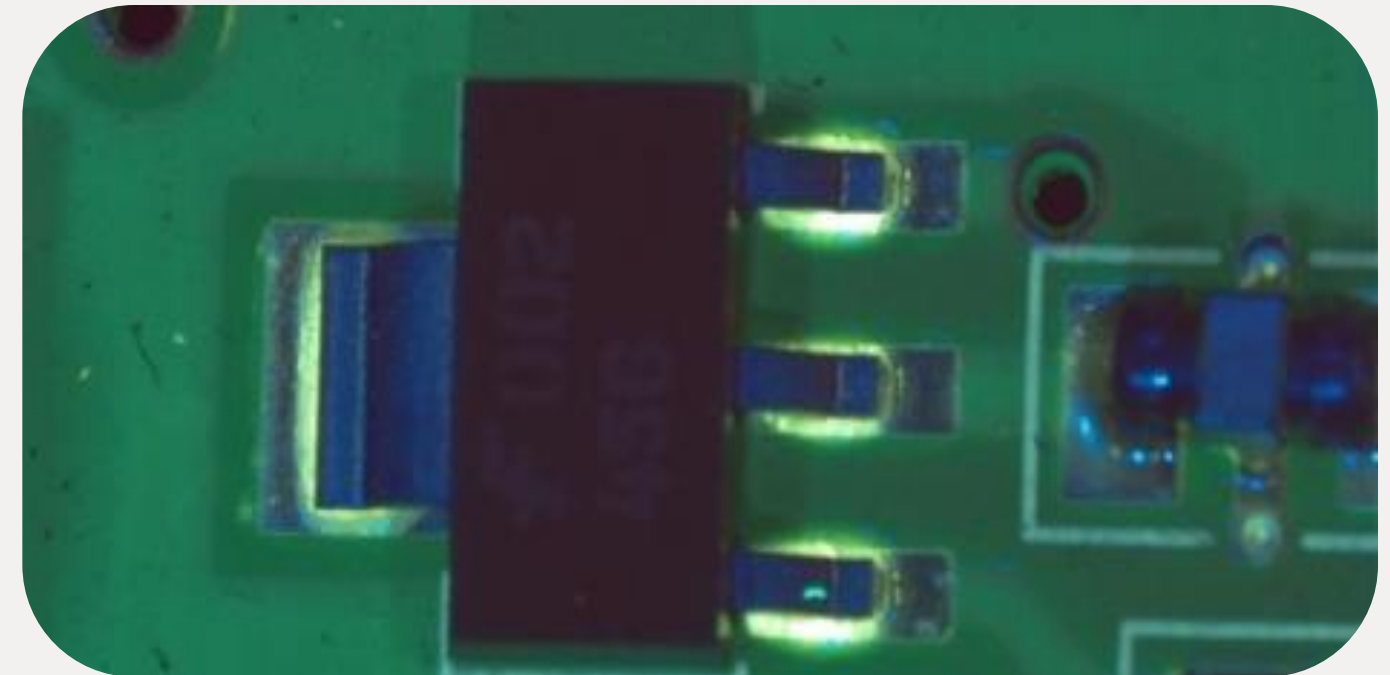

Blue Light Fluorescence Highlighting Epoxy



Gravity-fed Precision Sectioning Machine

IsoMet Low Speed
Manual Sectioning



IsoMet 1000
Low Speed Sectioning



PetroThin
Petrographic Sectioning



IsoMet High Speed
Automatic Precision
Sectioning



AbrasiMet M
Manual Abrasive
Sectioning



AbrasiMet L
Automatic Abrasive
Sectioning

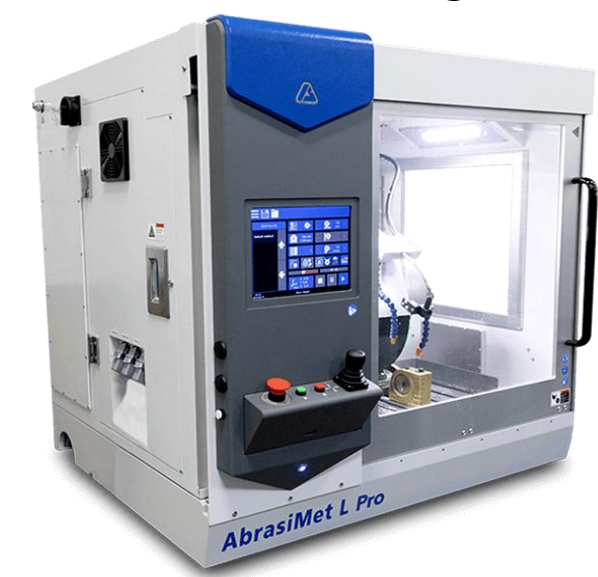



SimpliVac
Cold Vacuum Mounting



Compression Mounting
Compounds



Acrylic Systems

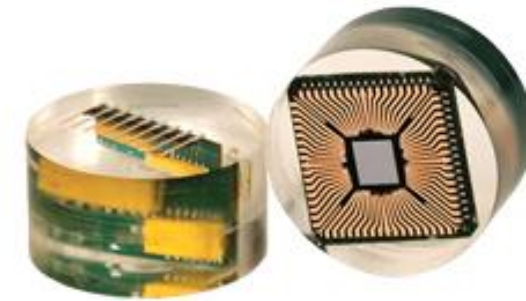

Epoxy Systems



SimpliMet 4000
Hot Vacuum Mounting



Release Agent



Mounting
Accessories



PetroBond



EcoMet 30 Semi-Auto

The user-friendly touchscreen interface puts all regularly used functions on the simple front screen menus reducing process time.



IsoMet 30 Twin

All EcoMet/AutoMets have durable construction for reliability in high use environments, unique quick cleaning features, and plenty of enhancements for user-friendly operation.



VibroMet 2

Prepares high-quality polished surfaces on a wide variety of materials. Supports sample preparation for EBSD Analysis



AutoMet 250/300

Designed for manual or automated sample preparation. Simplicity is balanced with versatility to accommodate many applications and larger areas.



Wilson Vickers & Knoop VH3300

- Fast, user-friendly operation for all skill levels
- Advanced features for flexible testing
- Integrated DiaMet™ software for comprehensive analysis



Wilson Vickers & Knoop VH3100

- Collision-resistant system protects indenter and objectives
- Fully integrated hardware and software platform
- Complete, all-in-one hardness testing solution



Wilson Micro Hardness VH1102, VH1150 & 1202

- Supports both Vickers and Knoop testing methods
Reliable, cost-effective microhardness testing
Ideal for quality control and metallurgical applications





Wilson Universal Hardness Tester UH4000

Can perform several different hardness scales in one machine including Vickers, Knoop, Brinell and Rockwell, in most cases at higher loads



Wilson Rockwell 2000 Hardness Tester

Achieve the highest level of depth measurement accuracy and resolution available and as a result has the best GR&R performance in the industry.

This machine is offered in two sizes ranging from 10 - 14 in of vertical testing capacity to accommodate varying sample sizes and is available in three different variations of Rockwell Regular, Superficial, or Twin hardness scales.



Wilson Brinell Hardness Tester BH3000

Designed with rugged construction to withstand harsh environments, the reliable BH3000 Brinell hardness testing machine combines high rigidity and closed-loop load cell technology to ensure accurate and safe load applications.

Diamet Hardness Testing

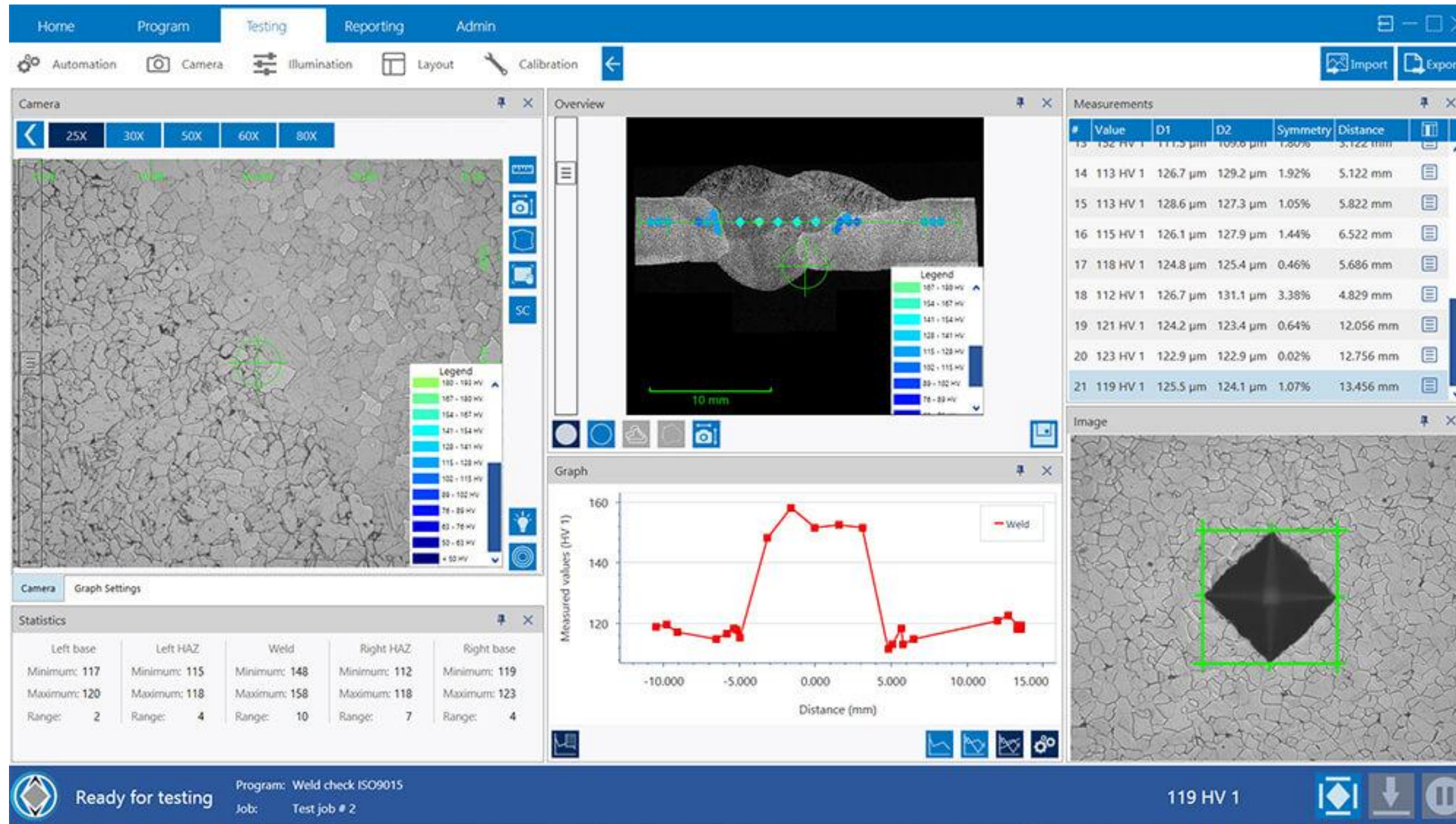

DiaMet hardness testing software breaks from the usual approach by offering a fast and simple way to perform hardness tests. This makes it easy for less experienced operators to use, while still providing the flexibility and advanced features that expert users need.



Consumables for Material Preparation Testing and Analysis

- Sectioning
- Mounting
- Grinding & Polishing
- Hardness Testing

Full Lab Metallography Solutions

- Grinding and polishing discs
- Precision sectioning blades compatible with most manufacturer's equipment
- Polishing compounds for virtually any application
- Epoxy or Acrylic based mounting compounds
 - 2-part, heat cured, and compression technologies



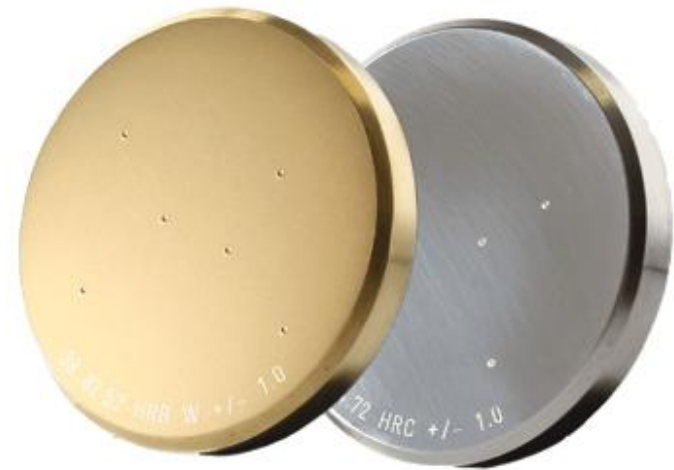

Wilson Rockwell Test Blocks

- We work directly with the steel and brass mills to specify the chemical composition.
- Our machining processes (grinding, lapping, polishing) are all done in house, at the site of calibration.



Wilson Vickers & Knoop Test Blocks

100% inspection to ensure that every single test block meets the physical requirements of ASTM (thickness, flatness, parallelism, surface roughness).



Rockwell Hardness Testing Calibration Kits

Contain three test blocks (low, medium, and high), an indenter, and a case. Each component can also be purchased separately and has its own part number.



Wilson Brinell Test Blocks

- Uniform material
- Grid pattern supports NADCAP compliance
- Large block size



- Flexible platform with pre-configured software or hardware packages and optional accessories
- Optional Capture and Measurement Modules available to customize software solution
- Any standard format image may be viewed directly from a calibrated microscope or be imported into OmniMet for analysis

86-1-1001	86-1-1000	OmniMet Viewer allows networked users to view and modify images and information in an Omnimet database on the same network.
	86-1-1010	OmniMet Capture N' Measure (CnM) enables image capture with basic measurement functions and scale bar (without database functions). Measuring tools include length, parallel lines, curved line, area, perimeter, radius, angle and count. Images can be saved in common formats. Results can be burnt into the image but cannot be stored or exported to Excel®.
86-1-1003	86-1-1002	OmniMet Basic includes everything in Capture 'N Measure, and also adds databasing functionality for archiving as well as MS Office report templates for presenting results. Optional Capture Modules may be added for specific applications.
86-1-1005	86-1-1004	OmniMet Advanced includes everything in OmniMet Basic, and also adds enhanced measurements capabilities. Measurements can be saved in the database, or interactively to Excel worksheets. Built in statistical analysis streamlines interpretation of results and reporting. Optional Capture Modules and Advanced Measurement Modules may be added for specific applications.
86-1-1007	86-1-1006	OmniMet Express includes everything in OmniMet Advanced, with the added capability of running automated Scripts. Scripts are application specific image analysis packages to provide best efficiency and reproducibility for repeat analysis in high throughput environments. Optional Capture Modules, Advanced Measurement Modules and pre-programmed Application Specific Scripts may be added.
86-1-1009	86-1-1008	OmniMet Enterprise includes everything in OmniMet Express, with the added capability of writing and editing Scripts. Fully customizable Scripts allow the user complete control of analysis solutions. Comes with 8 commonly used Application Specific Scripts. Optional Capture Modules, Advanced Measurement Modules and additional Application Specific Scripts may be added.

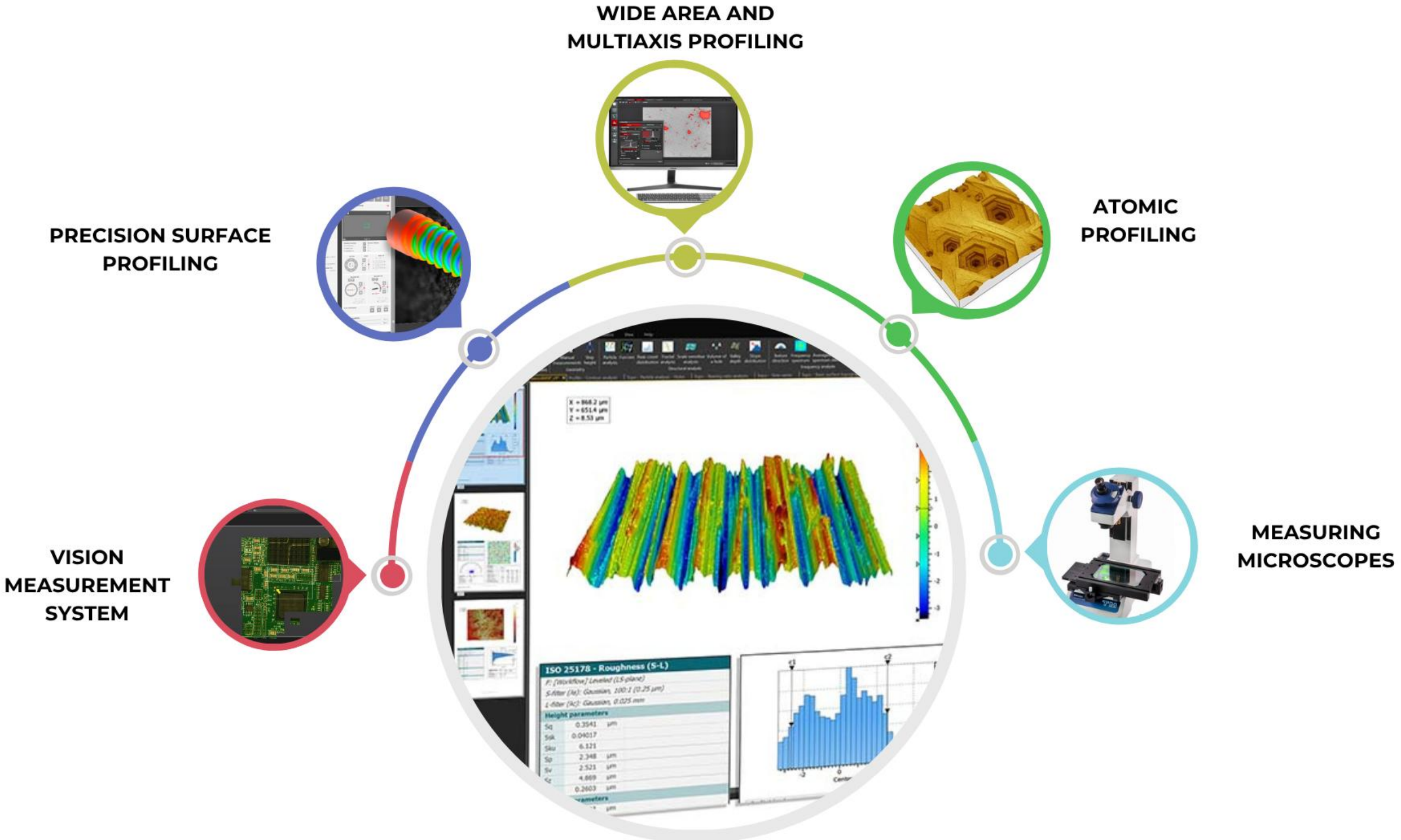



QuickScope & Quick Image

- Manual/Semi-Auto
- Errors due to focusing are eliminated
- Simple execution of multiple measurements



Mitutoyo Quick Vision Active

Compact CNC Vision combines the flexibility of multiple zoom lenses with touch probe capability to provide a versatile measuring system

- Programmable LED stage and coaxial light
- 4-quadrant LED ring light
- High-resolution and high-speed color camera

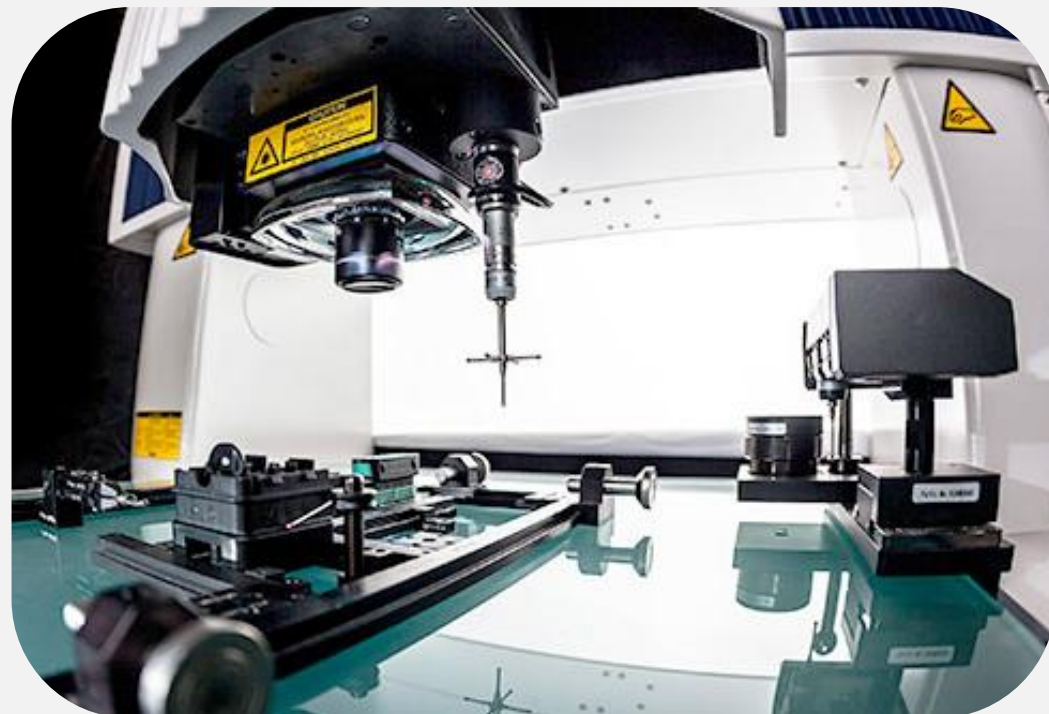

Quick Vision Hyper

- Programmable Power Turret (PPT)
- Tracking Auto Focus (TAF)
- Programmable Ring Light (PRL)



Quick Vision Stream Plus

Innovative vision measuring machine that gains images without stopping the stage.



Sensofar S neox

Configurations available:

- Confocal
- Interferometry
- Focus variation
- Layer Thickness



Sensofar S lynx 2

Compact precision surface profiling featuring nano-scale accuracy at an affordable cost

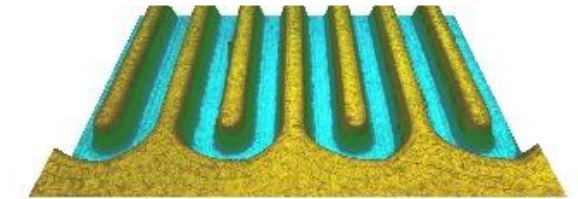

Sensofar S neox Grand Format

A high-performance, non-contact 3D optical profiler designed for advanced surface metrology applications of large panels in semiconductor, display, and PCB industries.

The S neox Grand Format Cleanroom provides three different optical technologies to image with the most suitable technology for each specific sample, achieving precision down to sub nanometer levels.



Nano-Observer II Atomic Force Microscope

High-performance Atomic Force Microscope designed for advanced nanoscale imaging and characterization across a wide range of materials and applications.



Galaxy Dual Controller – AFM Upgrade Platform

Powerful upgrade solution that modernizes legacy AFM and STM platforms while unlocking advanced measurement modes previously unavailable on older systems.

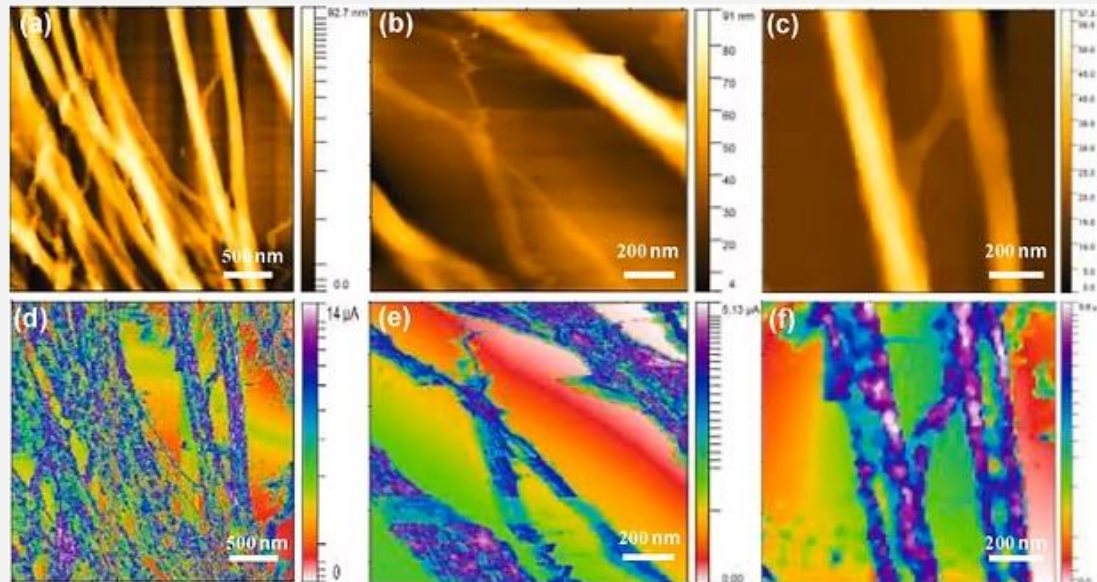

AFM Systems for Advanced Nanoscale Research

Systems provide a scalable platform for nanoscale characterization—from routine imaging to advanced electrical and functional analysis.



Sensofar S wide

The S wide system uses Fringe Projection technology to quickly acquire large-area measurements with high vertical resolution. It includes analysis tools to extract data on roughness, flatness, critical dimensions, GD&T, and CAD comparisons.



Sensofar S neox Five Axis

Optical profiler combines a high-accuracy rotational module with the advanced inspection and analysis capabilities of the S neox 3D optical profiler. This enables automatic 3D surface measurements at defined positions which can be combined to create a complete 3D volumetric measurement.



Toolmakers Measuring Microscope

Well suited for measuring dimensions and angles of machined metals.



Manual Measuring Microscope

- Measure multiple workpieces simultaneously
- Simple go/no-go judgment of multiple workpieces
- Generate reports and observe all in one instrument



Motorized High-accuracy Measuring Microscope

User-friendliness, high measurement data throughput, and environmental friendliness

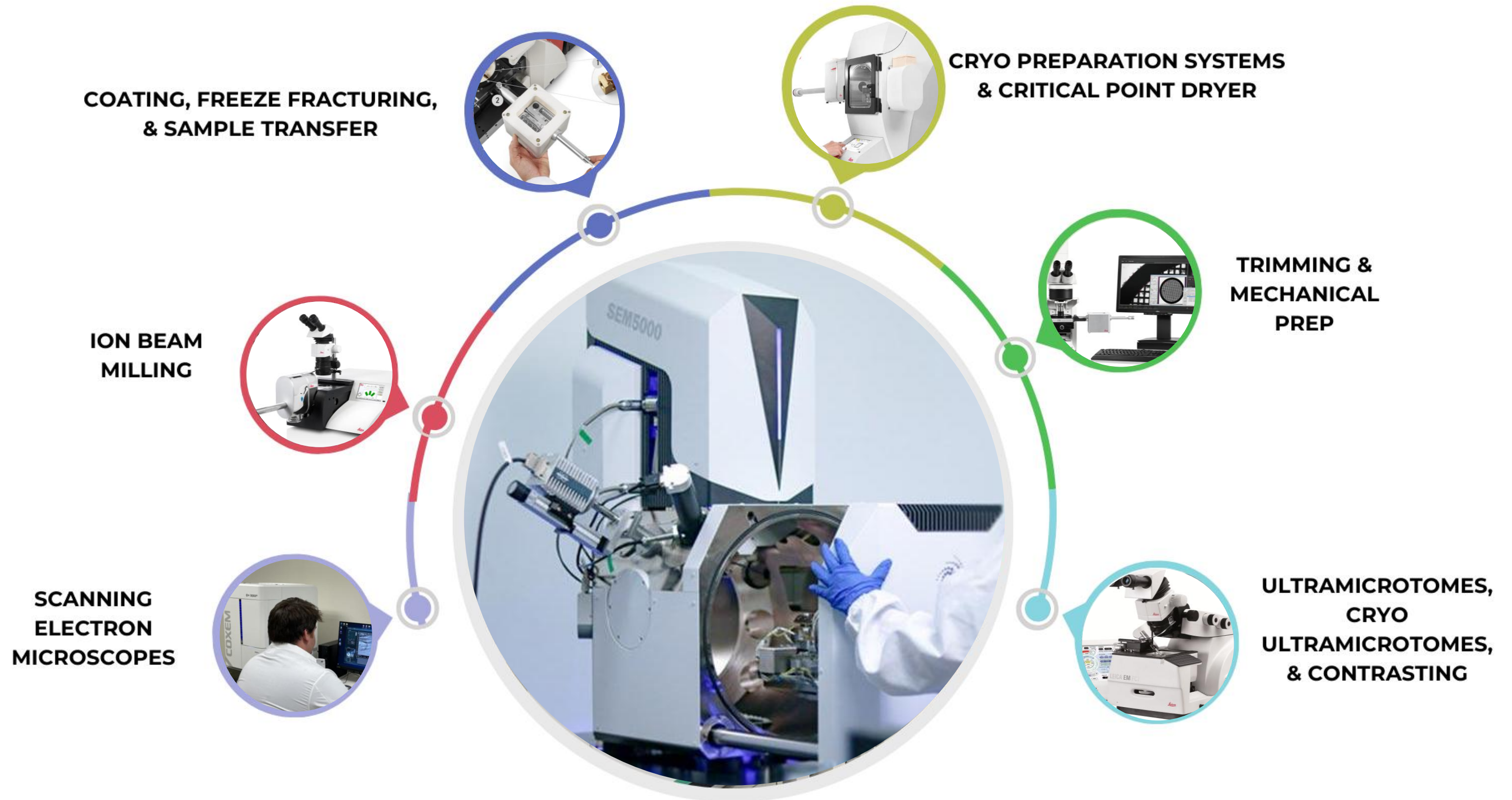

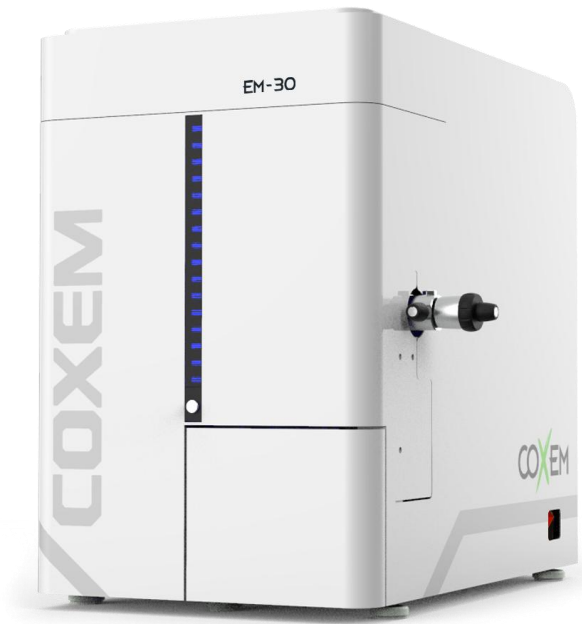

EM-30N Table-top SEM

With specifications and capabilities not matched by any other SEM in its price range. After evaluating the EM-30 Series your search will be over to find the best compact SEM available.



CX-200K Compact SEM

The standard supplied configuration of the CX-200plus includes both SE and BSE imaging detectors and an internal chamber view camera for easy stage tilt and height adjustments.



EM-40 Table-top SEM

New standards for compact, benchtop, and desktop SEMs by offering you advanced features typically found only in larger, more expensive models.



CX-300K Compact SEM

Up to 100mm X,Y travel in a compact size



Focused Ion Beam SEM (FIB-SEM)

The CIQTEK DB550 is an advanced Field Emission Scanning Electron Microscope (FE-SEM) with Focused Ion Beam (FIB) capabilities, offering comprehensive nano-analysis and fabrication in a single workstation.



Full Size Field Emission SEM

The CIQTEK SEM5000X is an ultra-high resolution Field Emission Scanning Electron Microscope (FESEM) with optimized electron optics that reduce aberrations by 30%, enabling 0.6 nm resolution at 15 kV.



Full Size Tungsten SEM

The CIQTEK SEM3300 is a next-generation tungsten filament scanning electron microscope that combines in-lens electron detectors with electrostatic and electromagnetic compound objective lenses, enabling low-voltage analysis previously only available in field emission SEMs.



High Speed SEM

The CIQTEK HEM6000 integrates advanced technologies—high-brightness large-beam current electron gun, high-speed beam deflection, high-voltage stage deceleration, dynamic optical axis, and a hybrid immersion objective lens—to deliver fast imaging with nanoscale resolution.



EM TIC 3X

Allows production of cross sections and planar surfaces for Scanning Electron Microscopy (SEM), Microstructure Analysis (EDS, WDS, Auger, EBSD) and, AFM investigations.



EM TRIM2

High-speed milling system with an integrated stereomicroscope and LED ring illuminator for trimming biological and industrial samples prior to ultramicrotomy.



IP 10000

An advanced sample preparation tool that etches a cross section of a sample using an argon ion beam.



EM TXP

Target Surfacing System, target preparation device for milling, sawing, grinding, and polishing samples prior to examination by SEM, TEM, and LM techniques.



EM ACE200

Low vacuum sputter and carbon thread coater, producing homogenous and conductive metal or carbon coatings for SEM and TEM analysis was never before more convenient



EM ACE600

High vacuum sputter coater processes yield reproducible results you can trust and enable you to increase your sample output with every run.



SPT-20

The SPT-20 Sputter Coater is a compact ion coating system ideal to support table-top SEM's. The system is able to sputter noble metals such as gold (Au), palladium (Pd), platinum (Pt), and silver (Ag) for non-conductive or poorly conductive specimens.



DSTI-170

The high-vacuum magnetron desk sputter coater model DSTI-170 is a compact coating system with the ability to coat metals (Oxidizing and non-oxidizing), suitable for short-term deposition periods.



EM ACE900 Freeze Fracture System

- Cold shield around the sample avoids water molecules freezing onto your sample
- Accurate temperature control during the complete process
- Clean Knife – fresh blade for each cut avoids contamination



EM CPD300: Critical Point Dryer

- Automated drying system for biological and industrial samples
- Delivers consistent high-quality specimen preservation
- Features safe waste disposal system with no user contact



Leica EM VCT500

- Stay Connected
- Connect your workflow systems
- Optimize your sample transfer thanks to the active sample cooling and new valve concept
- Monitor your sample with respect to temperature and vacuum at any time during the workflow when docked



tousimis Critical Point Dryers

- Process large or numerous smaller samples
- Process large or numerous smaller samples
- Program and save custom recipes



UC Enuity Ultramicrotome | Products

The next generation ultramicrotome that saves your valuable time and resources through its automated setup functions, providing state-of-the-art sectioning quality.

EM FC7 Cryochamber

- Full control integration with the EM UC7 touchscreen control panel
- Highly stable temperature regulation and low LN2 (liquid nitrogen) consumption

Three different cryo-modes available for use:

1) standard, 2) high gas flow, and 3) wet cryo-sectioning



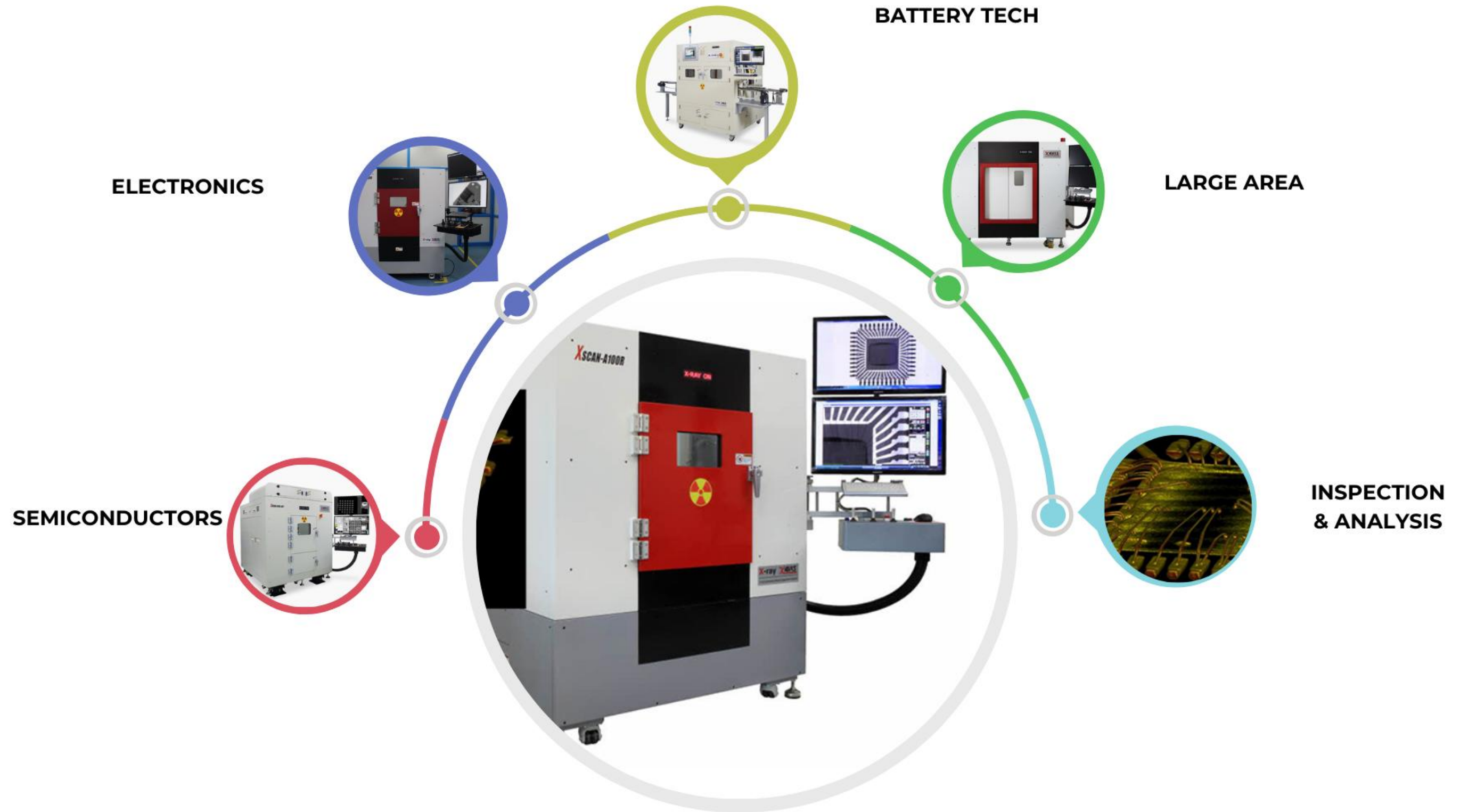



X-ray systems for Electronics

The XSCAN-A series consists of four advanced X-ray inspection systems (A100R, A130H, A150, and A100W).



X-Ray systems for Battery Technology

The XSCAN-9000 series offers four specialized X-ray inspection system variants (Prismatic, Cylindrical, Polymer, and Polymer Stack) designed for comprehensive battery and condenser inspection.



X-ray systems for Semiconductor

The XSCAN-H series offers three high-powered X-ray inspection systems (H130-OCT, H160-OCT, and H160M) featuring hybrid 2D/3D inspection capabilities with automation technology.



X-Ray systems for large area applications

The XSCAN C series encompasses four high-powered X-ray inspection systems ranging from 150kV to 225kV, designed for large-scale industrial applications.

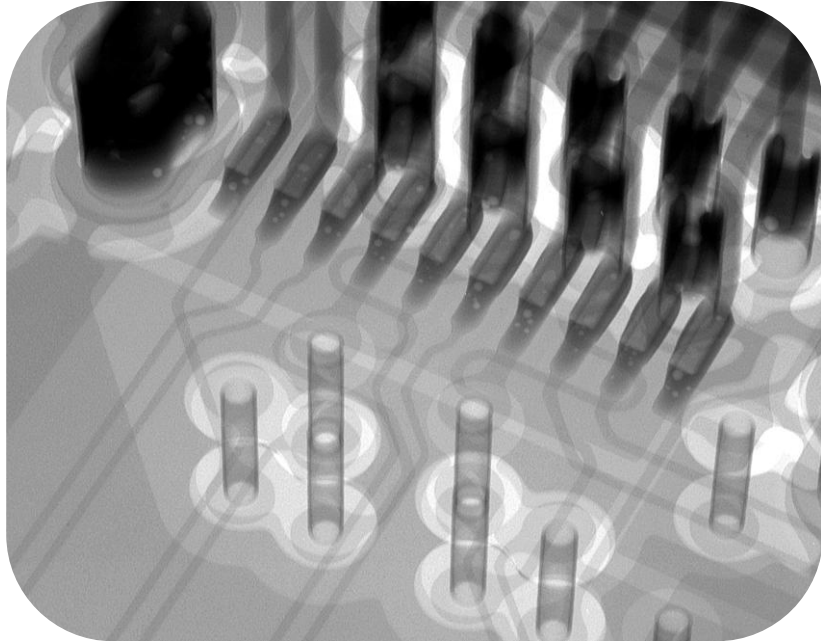

X-ray Voids Image

Solder Void Detection: These systems are particularly effective at identifying voids (air pockets) in BGA soldering and semiconductor packaging.

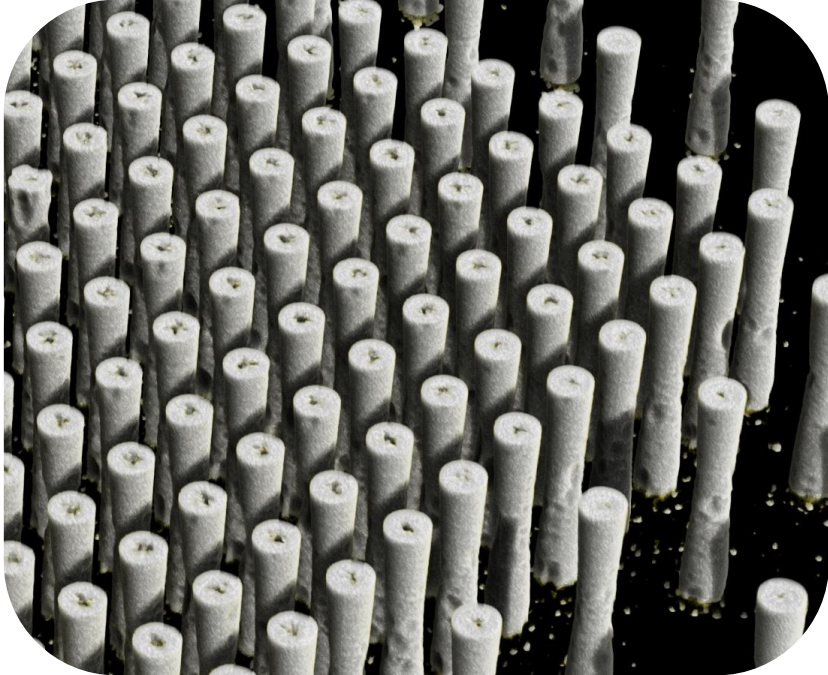

Oblique CT

The systems, such as the XSCAN-H160-OCT, utilize oblique CT technology to provide comprehensive views of the internal structure without destroying the component.

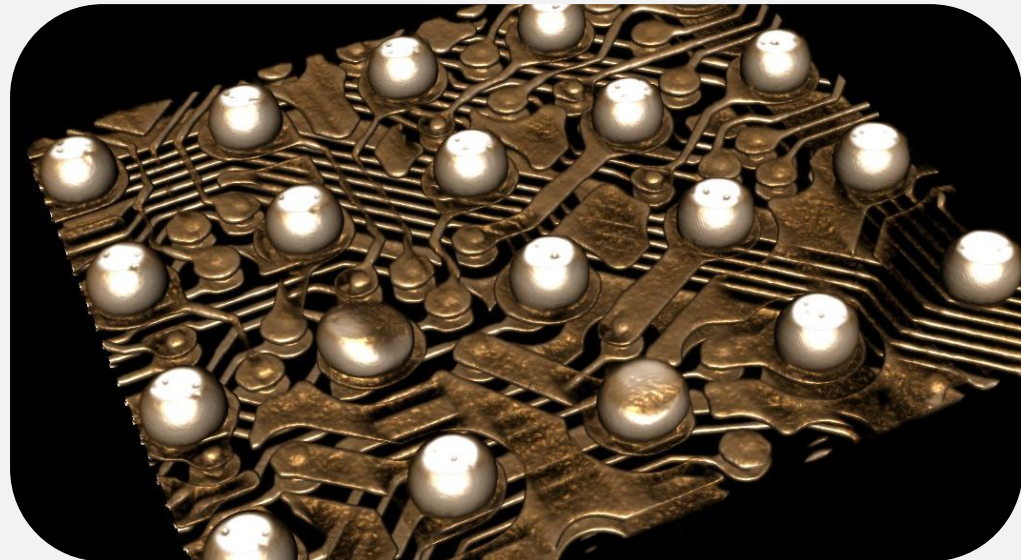

2D & 3D Imaging

XAVIS systems, including the H100-OCT and H160-OCT, provide both 2D and 3D (computed tomography/laminography) imaging to visualize hidden defects.

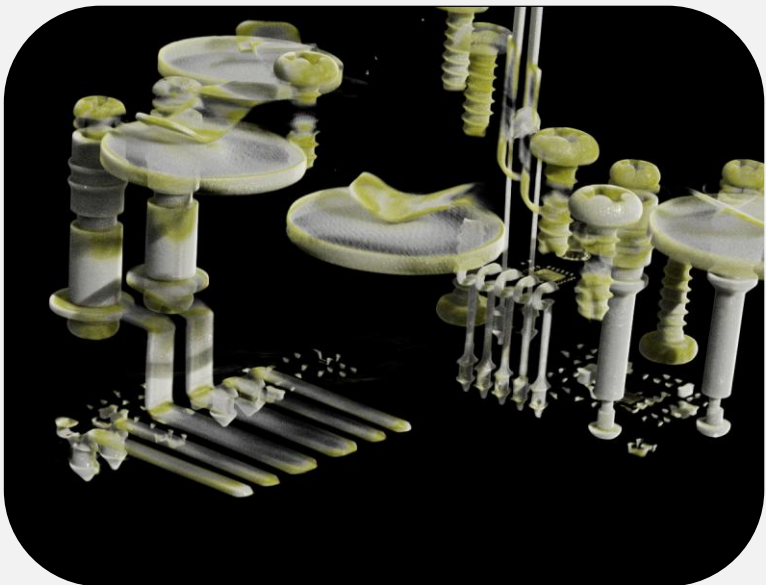

Cone Beam Computed Tomography (CBCT)

3D dental imaging technology that uses a cone-shaped X-ray beam to create highly precise, 3D images of teeth, jawbones, nerves, and soft tissue.

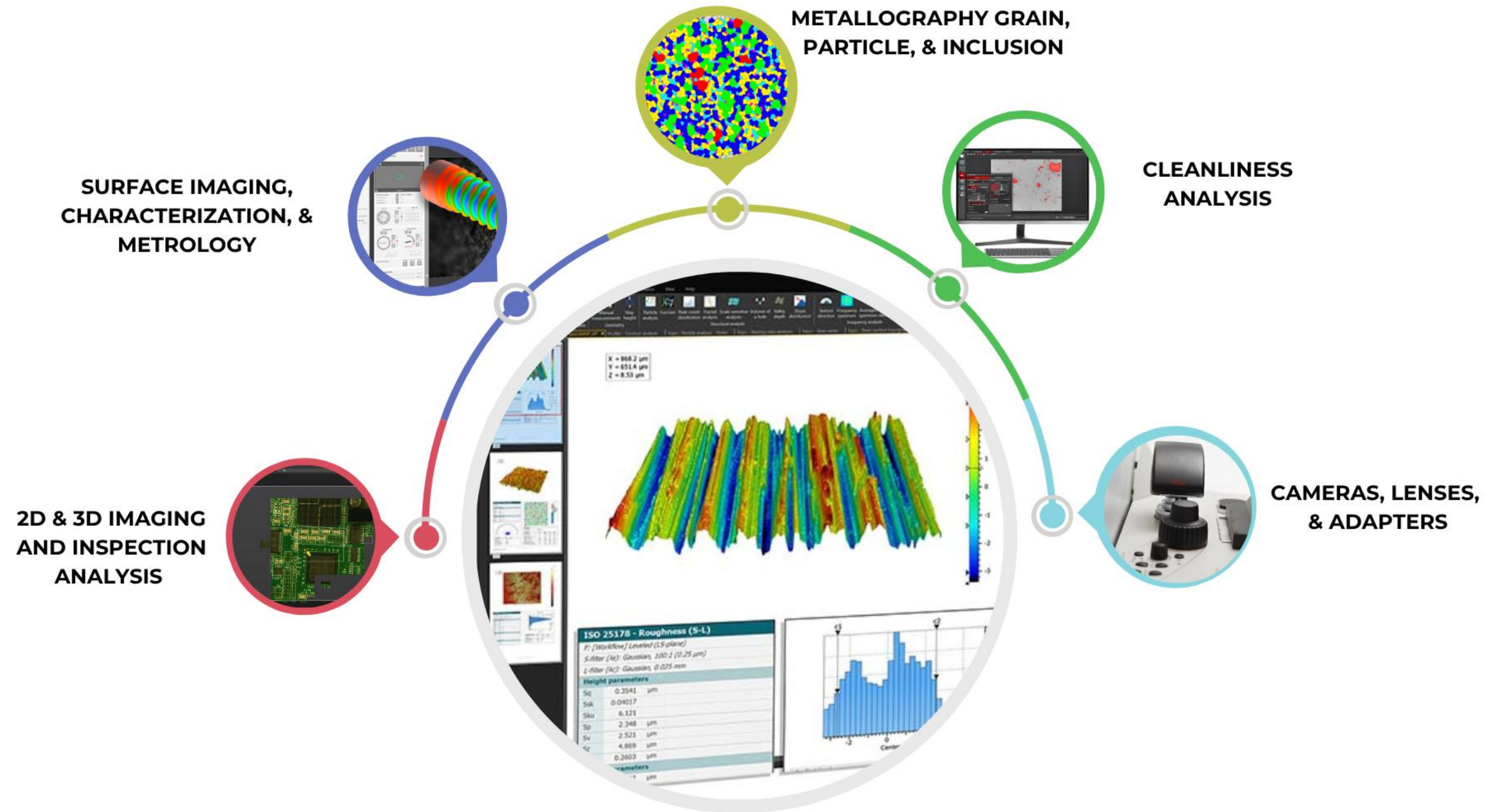



Energisight Microscope Software Platform

- Eliminates hassle of navigating different software across workstations
- Streamlines quality control and inspection workflows
- Unified platform for consistent operation



Consistent operation that saves you time

- Common interface works across multiple operation modes
- Features on-screen display (OSD) functionality
- Reduces learning curve and improves efficiency

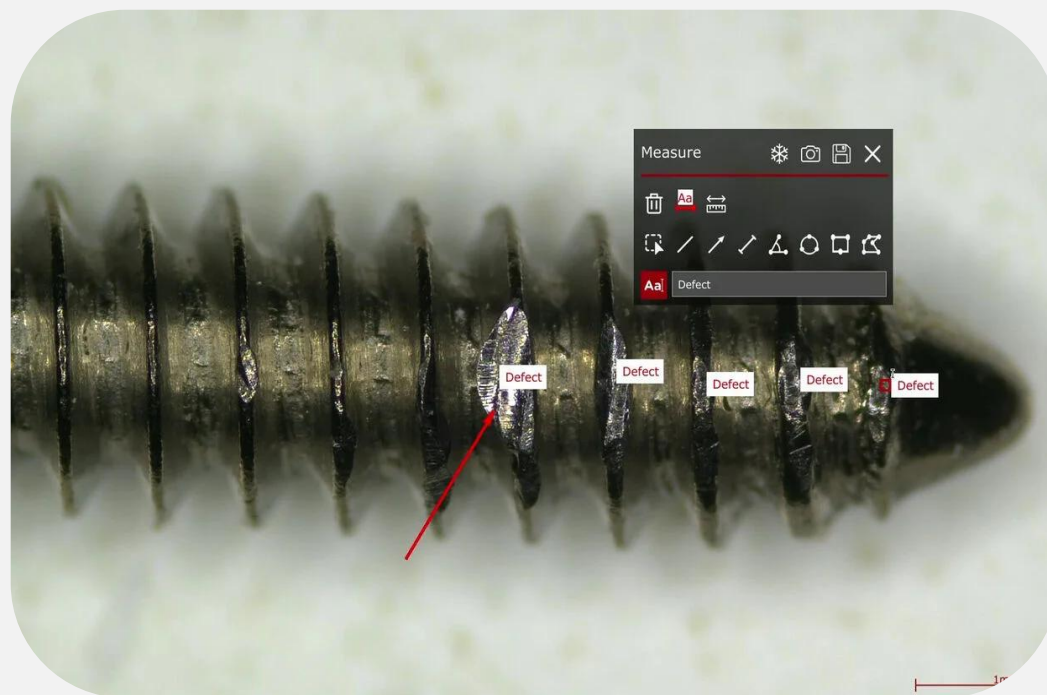

Inspection and Quality Control

- Simplifies and streamlines inspection and documentation workflow
- Provides consistent, easy-to-use interface for all quality processes

Streamline your inspection process

- All-in-one integrated software solution
- Improves inspection efficiency through streamlined tools
- Easily compare, measure, and share data across systems

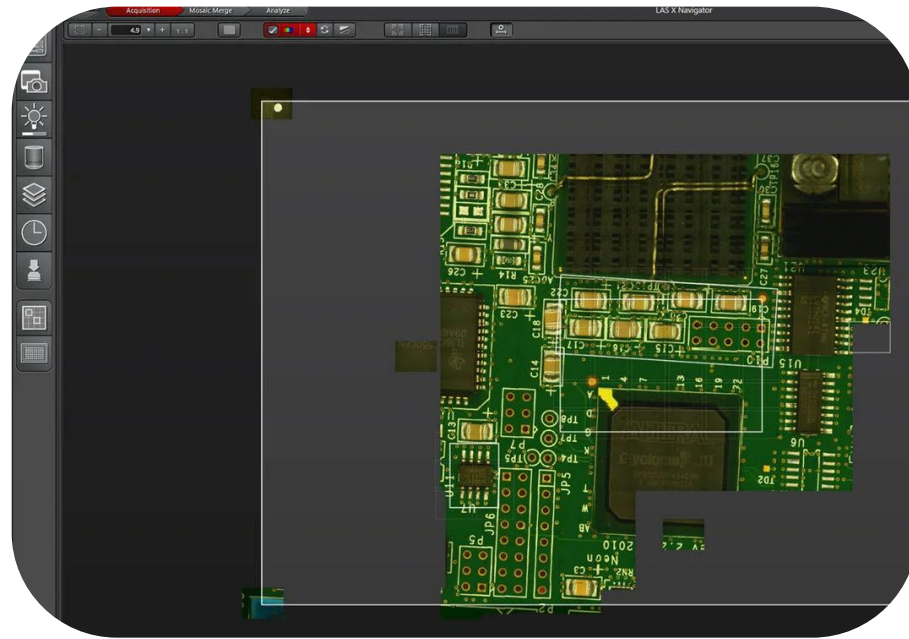

Leica LAS X

- LAS X Live Image Builder
- LAS X Z-Control & SW Autofocus
- LAS X Extended Depth of Field
- LAS X Stitching
- LAS X 3D Surface Viewer
- LAS X 3D Surface Measurements



Energisight Measuring Software

- Measure multiple workpieces
- Simple go/no-go judgement of multiple workpieces
- Generate reports all in one



Cleanliness Analysis Software Platform

Cleanliness analysis systems from Leica Microsystems offer optimized software and a unique 2-in-1 solution for visual and chemical analysis.

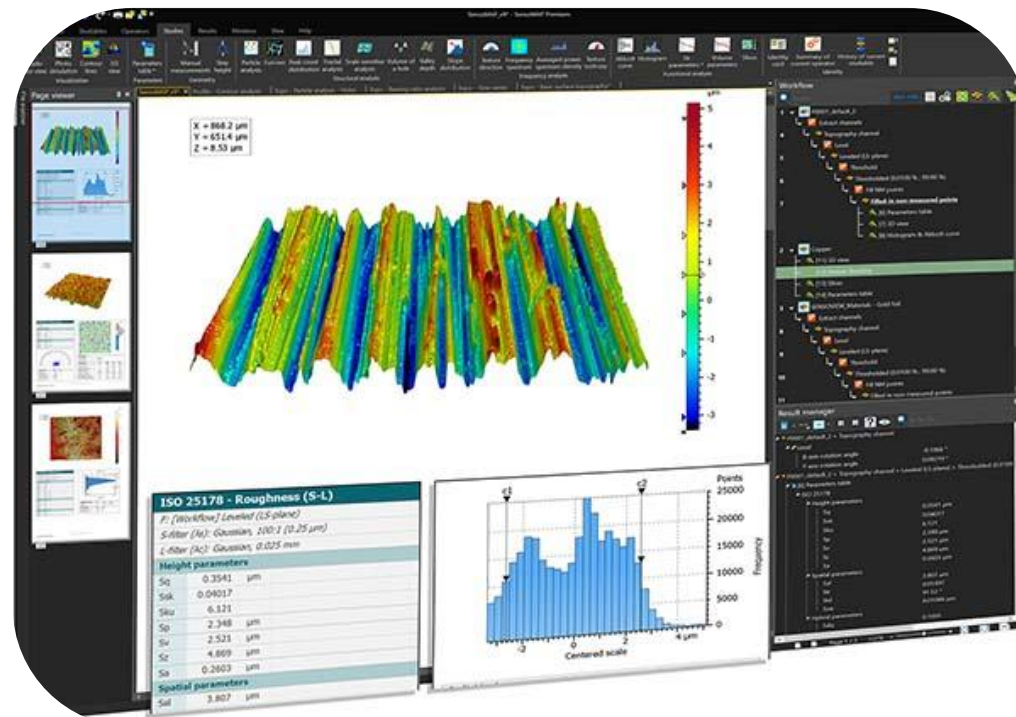

SensoMAP

Advanced Analysis Software

Based on Mountains technology from Digital Surf, which is an extremely powerful tool for analysis and reporting. Software provides 3D visualizations and characterization of surface features.

Leica Map

Used for viewing and analyzing surface geometry and surface texture from LASX depth map images.

Capabilities include 3D visualization of surfaces, characterization of basic surface features and calculation of surface texture parameters.

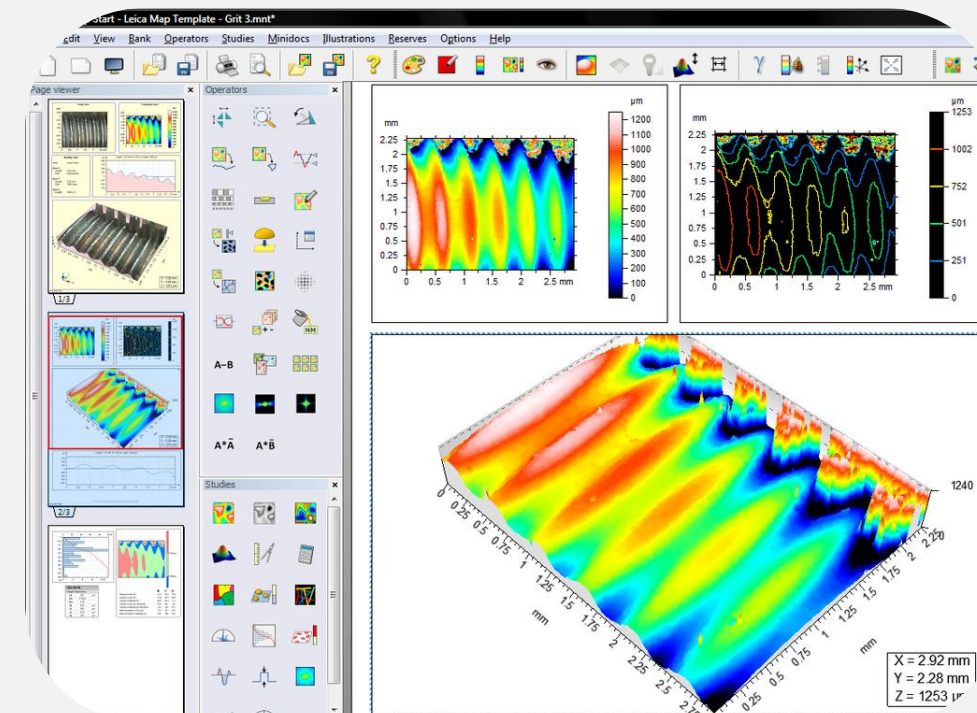

LAS X Modules

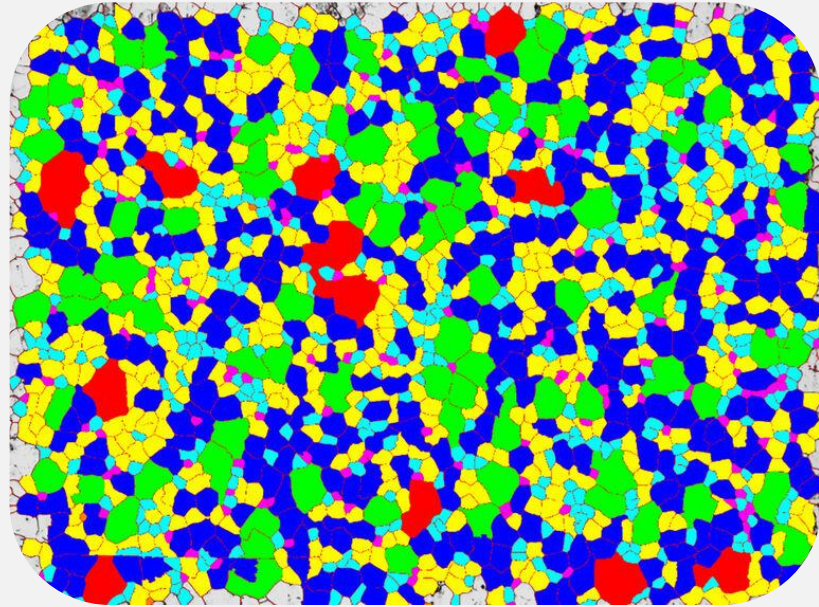

Cast Iron and Grain Expert

Identify graphite nodules and place them in size classes.

Analyze grain size to evaluate the properties of materials.

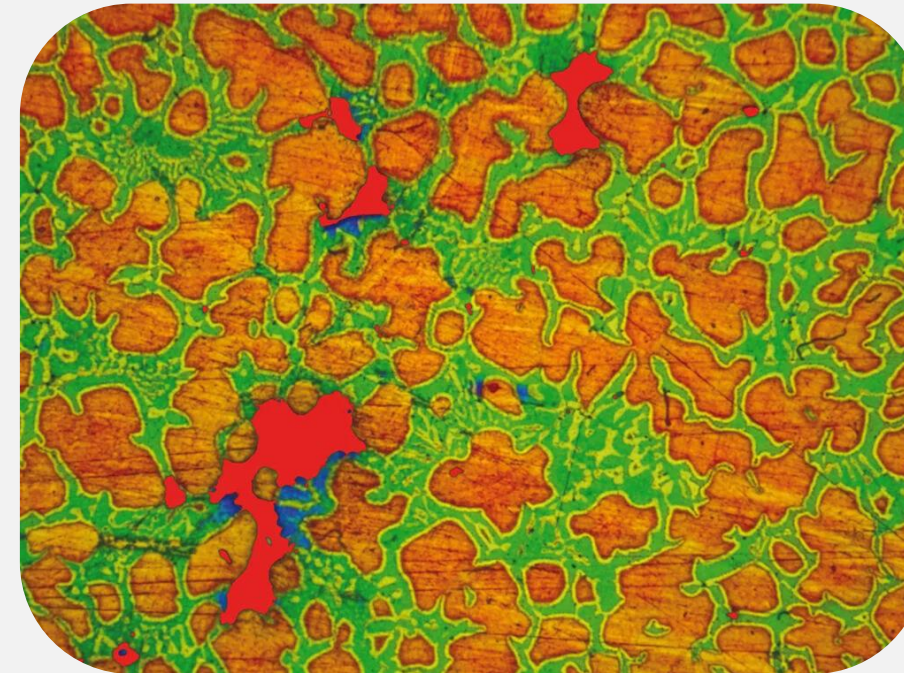

Phase Expert

Measure multi-phase microstructures identified by their distinctive color or contrast in materials.

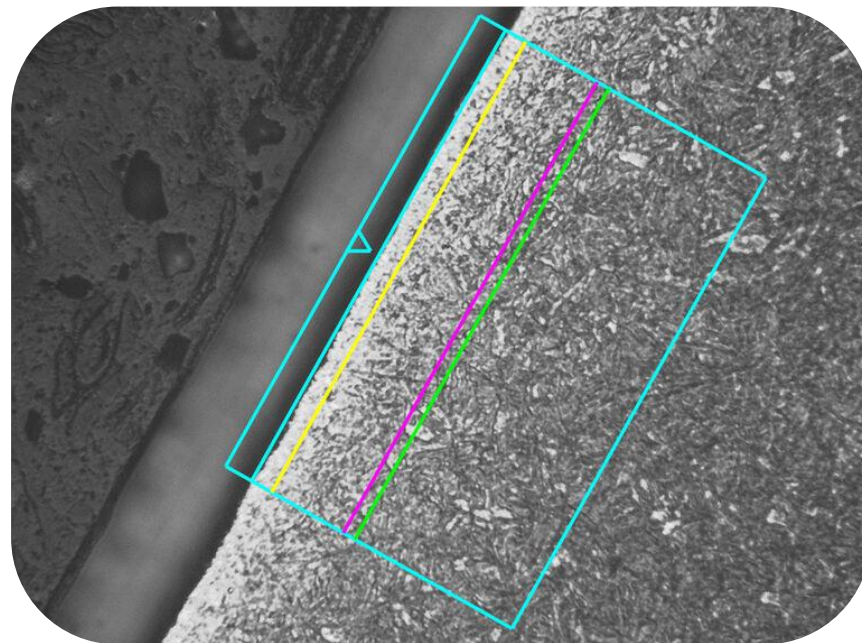

Decarburization

identify and analyze the depth of non or low-alloyed steel.

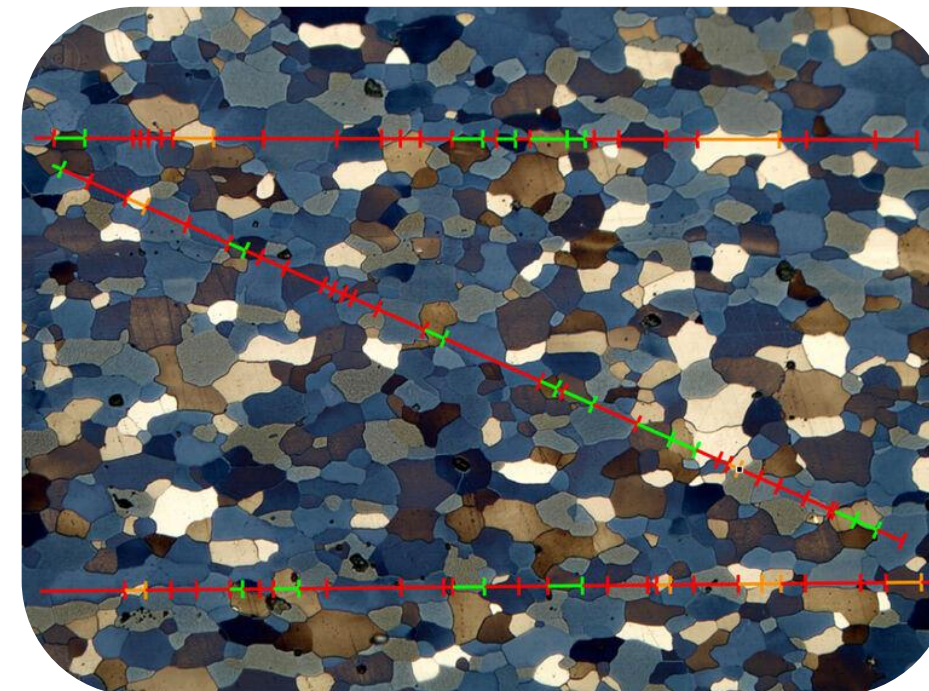

Metallography Toolbox

Assess, analyze, and measure metals, alloys, layers and coatings, adhering to laboratory requirements by incorporation analysis methods utilized in industry standards.



Target contamination fast

Cleanliness analysis systems from Leica Microsystems offer optimized software and a unique 2-in-1 solution for visual and chemical analysis.

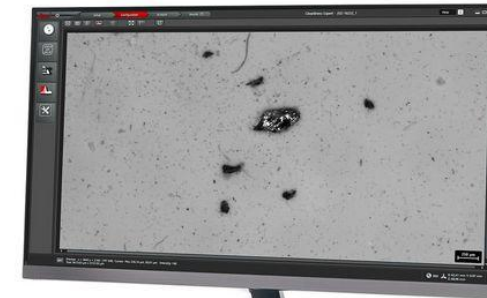
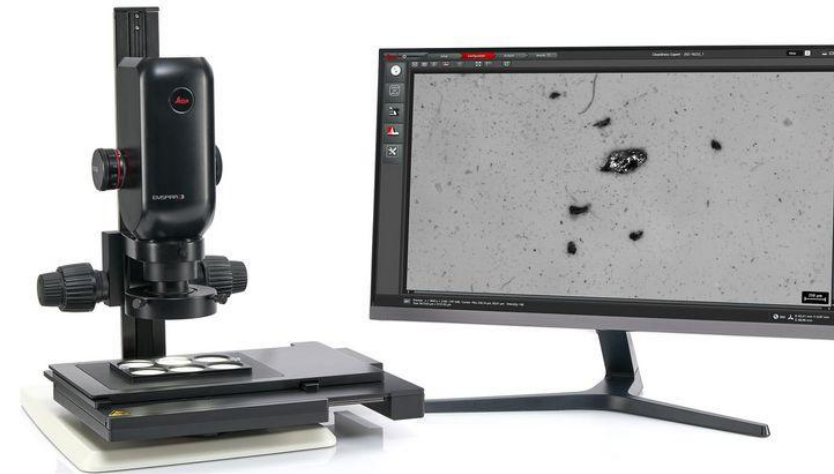

Your benefits

- Increase throughput by analyzing more in less time.
- Obtain more insights on the source of particles for better risk assessment and more confident decisions.
- Meet all your current needs and be prepared for changing requirements.

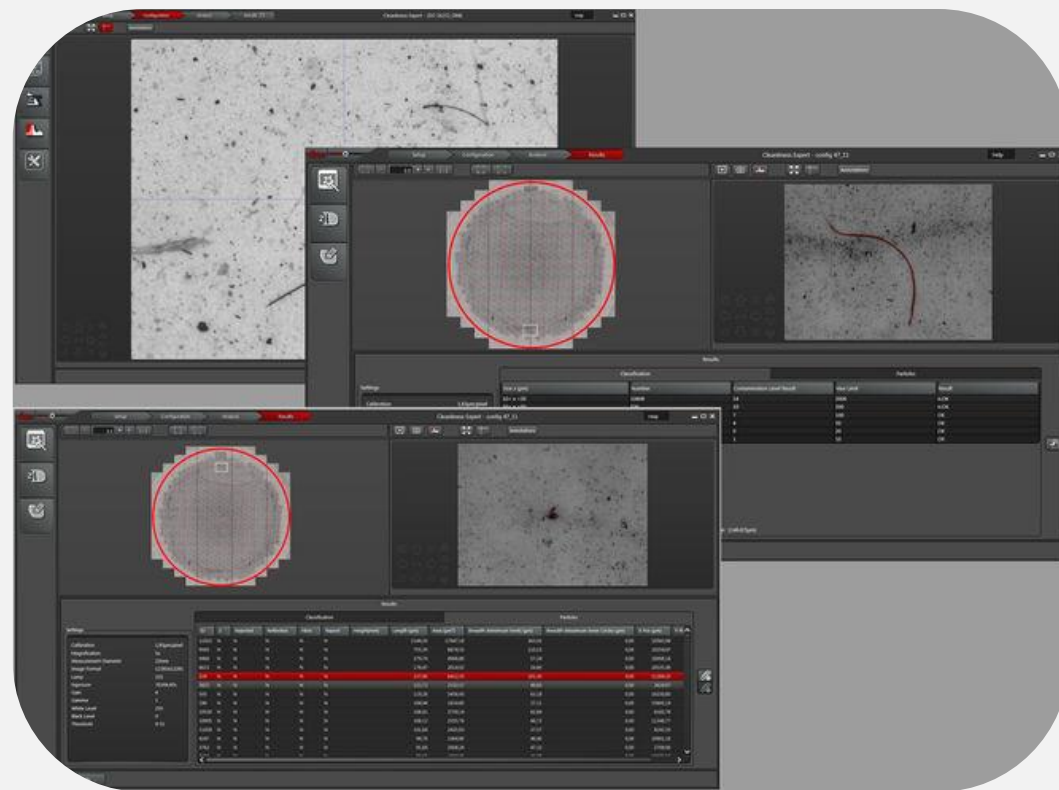

Ensure you get your cleanliness analysis results more efficiently:

- Save 30% of your filter sample scanning time for particle sizes between 5 - 10 micrometers.
- For particle sizes over 25 micrometers, you can scan particles on filter samples 3 x faster.
- Identify the reflective particle on your filter sample faster and calculate the circular diameter of irregularly shaped particles with improved speed thanks to optimized algorithms.

Camera Name	Flexacam C5	Flexacam i5 (stereo)	Flexacam i5 (compound)	K3C	K3M	K5C
Article Number	1270536	12730536	12730537			
						
Application	Education + Routine			High End Single Shot - Documentation and Analysis		
Resolution	■■■	■■■	■■■	■■	■■	■■■■
Speed	■■■	■■■	■■■	■■	■■	■■
Sensitivity	■■	■■	■■	■■■■	■■■■	■■■■
Interface	USB3	USB3	USB3	USB3	USB3	USB3
Type of Sensor	CMOS	CMOS	CMOS	CMOS	CMOS	CMOS
Surface Diagonal	7.81 mm	7.81 mm	7.81 mm	8.92 mm	8.92 mm	15.86 mm
FPS	60	60	60	15	21 (HW Trigger)	32
Cooling	No	No	No	No	No	No
A/D Converter	12 Bit	12 Bit	12 Bit	12 Bit	12 Bit	12 Bit
Exposure Time	1ms-125 ms	1ms-125 ms	1ms-125 ms	1ms-10s	1ms-10s	1ms-10s
Largest Capture	12 MP	12 MP	12 MP	6 MP	6 MP	20 MP
c-Mount Adapter	0.5x/0.55x	internal,0.5x	internal,0.5x	0.5x/0.55x	0.5x/0.55x	1.0x
Software PC	Energisight Desktop	Energisight Desktop	Energisight Desktop	LASX	LASX	LASX
Software Mac	-	-	-	Acquire	Acquire	Acquire
	Flexacam C5	Flexacam i5 (stereo)	Flexacam i5 (compound)	K3C	K3M	K5C



COLOR CHART & WHITE BALANCE



PARFOCALITY ADJUSTMENT FOR ALL MICROSCOPES



BEWARE OF "EMPTY" MAGNIFICATION



RESOLUTION TEST CHARTS & HISTORY



MIL TO MICRON CONVERSION TABLE

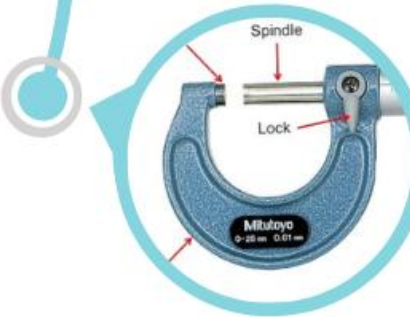

RESOLUTION CAPABILITIES





1. Human Eye (Unaided)

Maximum resolution:
Around 0.4 nm
(100 micrometers)



2. Stereo Microscope

Also known as a Dissecting
Microscope

Maximum resolution:
Around 1 micrometer (1,000
nanometers)



3. Compound Microscope

Also known as an Optical
Microscope

Maximum resolution:
Around 0.2 micrometers (200
nanometers)

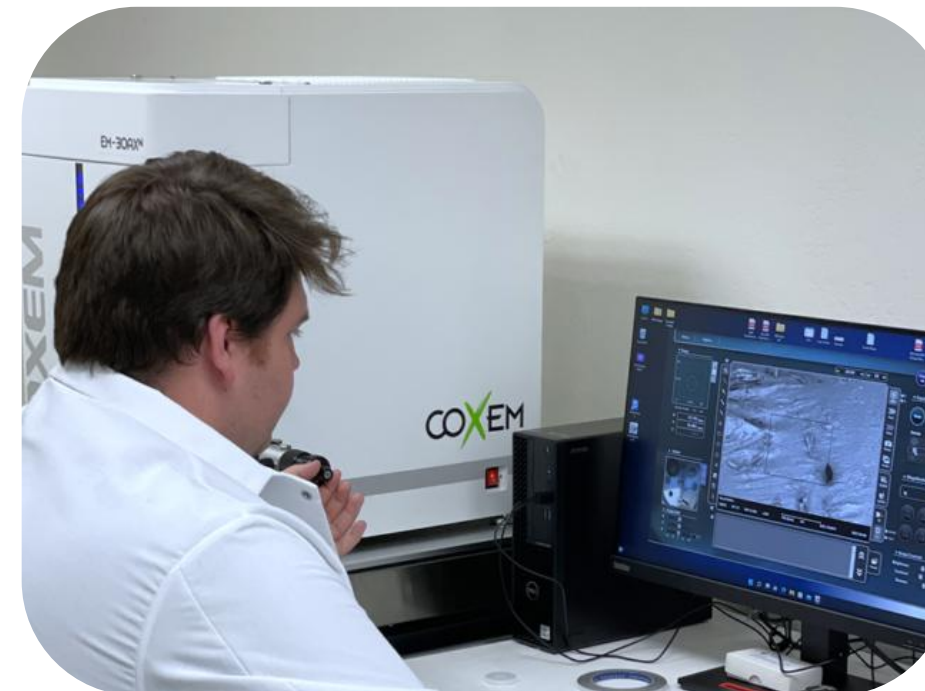

4. Scanning Electron Microscope (SEM)

Maximum resolution:
Around .5 nanometers
(0.5 billionths of a meter)

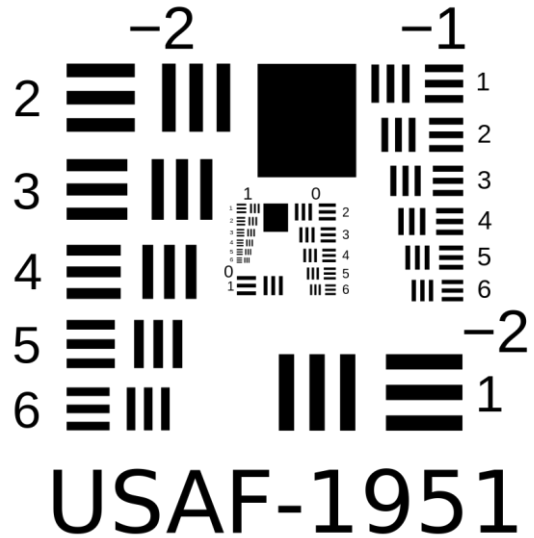

- Resolution test charts have been used since the late 19th century to evaluate and calibrate imaging system performance
- The 1951 USAF chart (MIL-STD-150A) uses stepped spatial frequency patterns to measure resolution in microscopes, cameras, and scanners

- The 1963 NBS (now NIST) chart evaluates resolution, contrast, and distortion
- Additional standards include ISO 12233 (digital imaging) and SEMI P28 (semiconductor inspection)
- Still widely used today to ensure consistent, high-quality imaging across microscopy and imaging applications

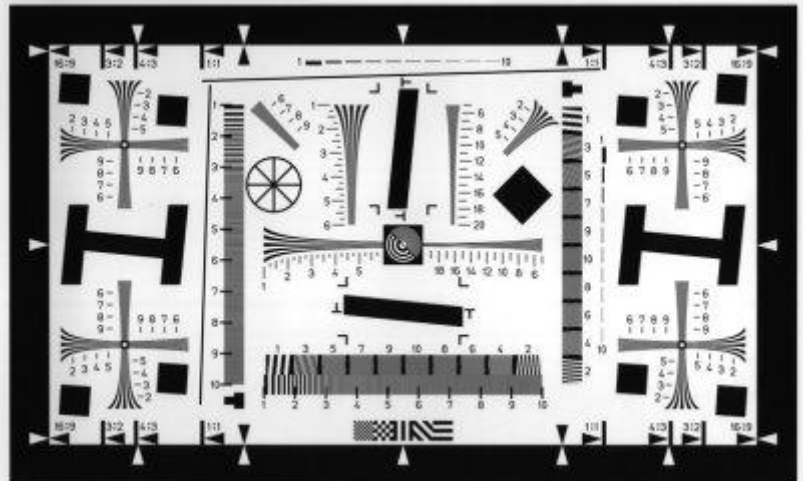

White Balance – What It Is and Why It Matters

A camera setting that defines what “true white” looks like under current lighting. It sets a baseline for all other colors, ensuring accurate, natural-looking images. Since white doesn’t always appear white in different lighting, this correction is essential.

What It Does:

- Applies to both photography and videography
- Adjusts all colors based on a defined “white”
- Prevents yellowish or bluish color casts

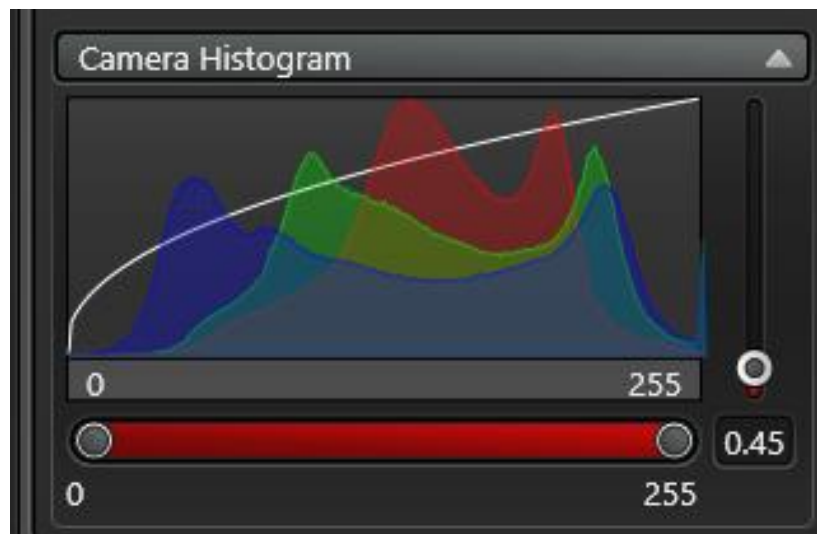
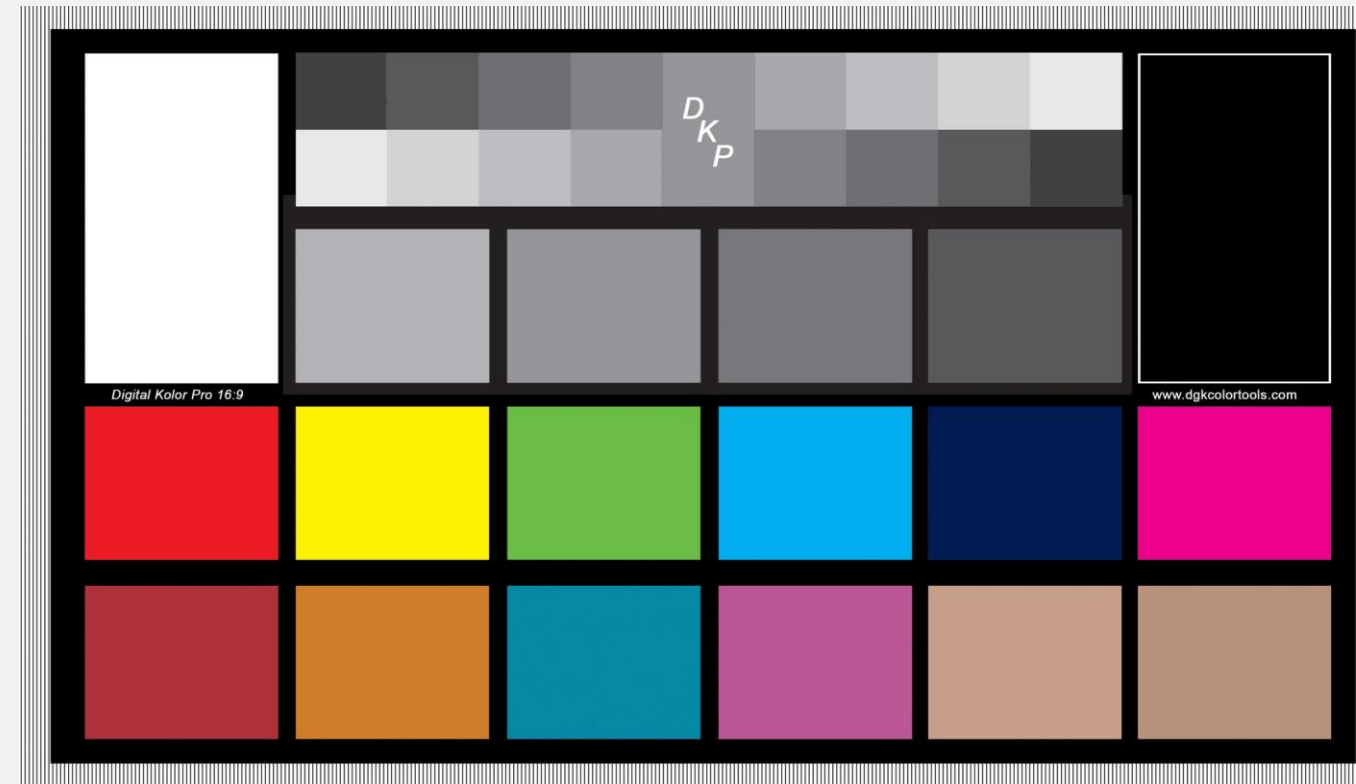

How It Works:

Auto White Balance (AWB): Most cameras default to AWB, which guesses what white is. It’s convenient but not always accurate—especially in mixed lighting.

Manual White Balance: For best results, use a white or grey card to manually set the balance. This tells the camera exactly what “true white” is in your scene, leading to more accurate color reproduction.

Parfocality Adjustment for All Microscopes

1. Set eyepiece diopter adjustment (lines on the side of eyepiece) to zero or where the two lines meet between the + and - signs. If only one eyepiece adjusts, just set that one. Some microscope may have adjustable eye tubes instead of adjustable eyepieces. In that case you will need to adjust the tube where the eyepieces go, not the eyepiece.



2. Go to the highest magnification on the microscope and focus on a sample. Preferably a thin, flat sample.

3. Now go to the lowest magnification on the microscope.

4. Close your left eye and adjust the right eyepiece (focus) until the image is sharp. Now repeat this process with the left eye. If the microscope only has one adjustment, you only need to adjust one side.

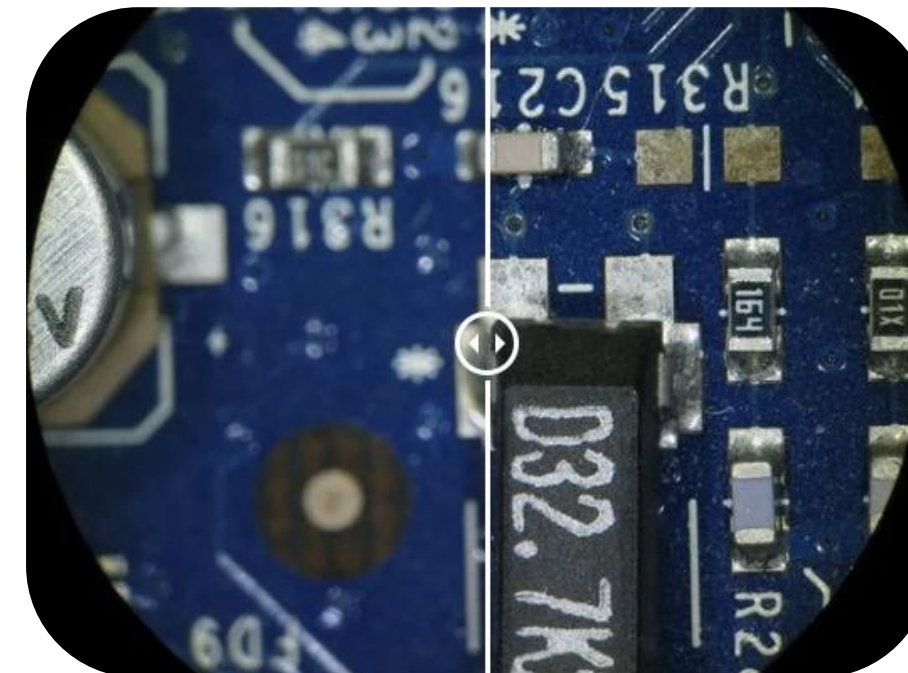

5. Check parfocality by going back to the highest magnification and focusing on a sample. Do not re-adjust eyepieces or tubes. Now go to the lowest magnification. The sample should stay in focus.



The numerical aperture of the objective determines the detail resolution and brightness of the image.

Light Wavelength Sets the Resolution Limit

- Microscope performance depends on resolution, not magnification
- Resolution = ability to distinguish two closely spaced points
- Per the Rayleigh criterion, minimum resolvable distance \approx half the wavelength of light

Blue light: $d \approx 0.2 \mu\text{m}$

Red light: $d \approx 0.35 \mu\text{m}$

UV objectives: just under $0.2 \mu\text{m}$

Human eye limit: $\sim 0.2 \text{ mm}$

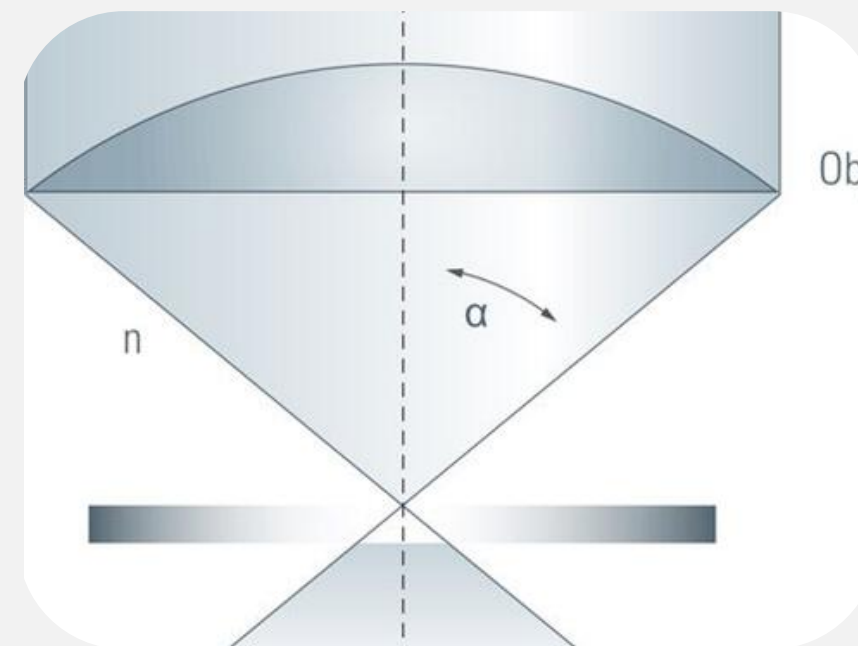

Resolution also depends on Numerical Aperture (NA), defined as:

$$NA = n \times \sin \alpha$$

- n = refractive index (e.g., $n_{\text{air}} = 1$, $n_{\text{oil}} \approx 1.5$)
- α = half the angular aperture of the objective

In air, $NA \approx 1$. With immersion oil, NA can reach ~ 1.45 , improving resolution.

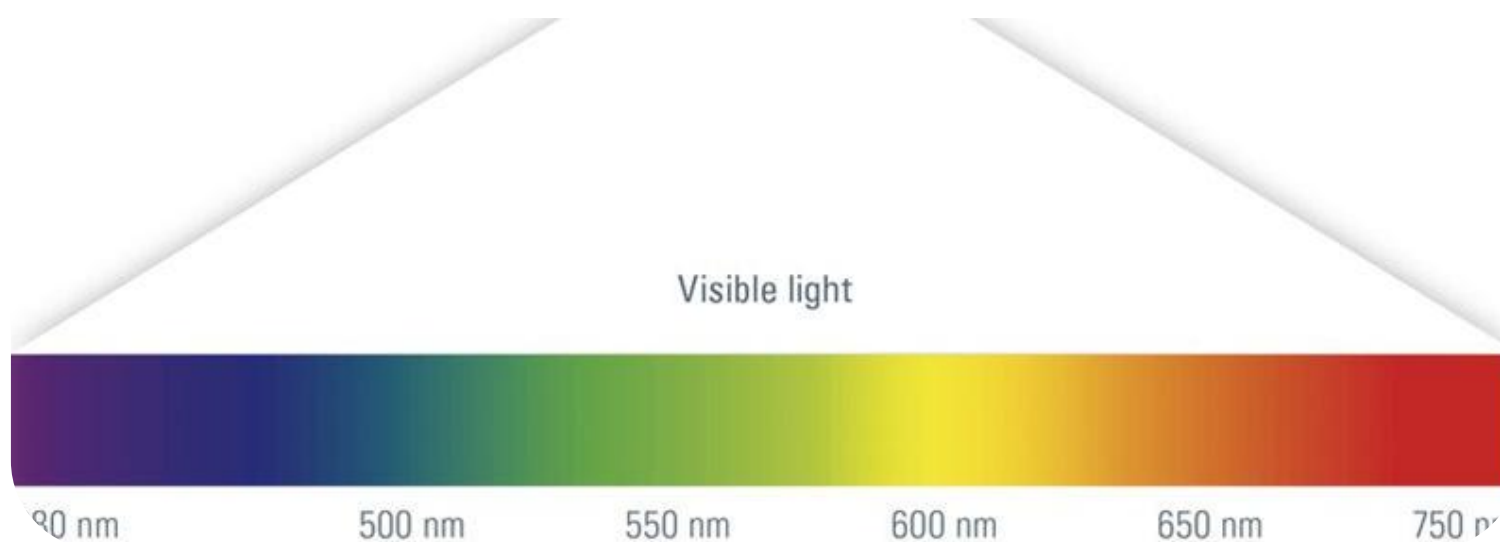

More Magnification is not Always Better

Magnification and Resolution in Optical Microscopy

A basic optical microscope uses two lenses:

- Objective (near specimen)
- Eyepiece (near eye)

Total magnification = objective × eyepiece

Example: 40× objective × 10× eyepiece = 400× magnification

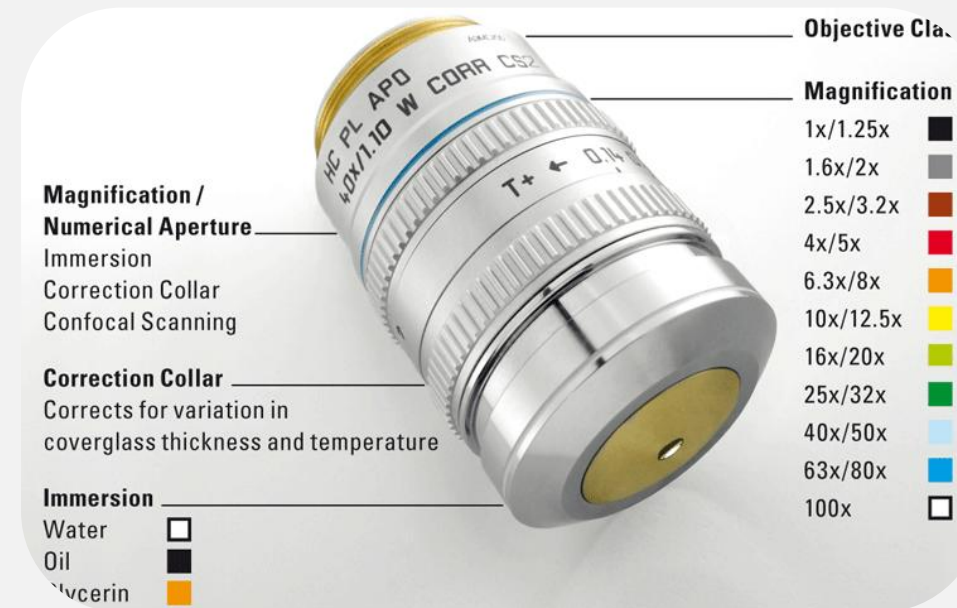

Resolution must be high enough to make magnification meaningful—**they are interdependent.**

- **Low magnification** = low numerical aperture (NA) = low resolution
- **High magnification** = high NA
 - Example: 40× dry objective typically has **NA ≈ 0.8**

However, NA has limits. So does **useful magnification**, which falls between:

500 × NA to 1,000 × NA

- Practical magnification limit: **~1,400×**
- Anything beyond = **"empty magnification"** (larger image, no added detail)

Example:

Hard metal (10% cobalt, 0.6 μm grain size):



(Courtesy of Konrad Friedrichs GmbH & Co KG, Kulmbach, Germany).

- Left View - Dry objective, NA = 0.90
- Right View - Oil immersion objective, NA = 1.30 (Oil improves resolution due to higher NA)

Is Magnification of 20,000x Really Useful with Digital Microscopy

Digital vs. Optical Microscopes

- Digital microscopes use a camera only—no eyepieces.
- Stereo and optical microscopes can be fitted with digital cameras for hybrid use.
- Both types serve diverse technical and industrial applications.



Digital systems may claim very high magnification (e.g., 20,000×), but true performance depends on resolution and optical quality, not just magnification numbers.



Magnification Defined

Magnification = **Image feature size / Actual feature size**

This gives **lateral (2D) magnification**.



The Best of Both Worlds
Microscopes with both camera and eyepieces offer digital convenience and allow visual color accuracy checks through the eyepieces.

Mil [mil, Thou]	Micron [μ]
0.01 mil, thou	0.254 μ
0.1 mil, thou	2.54 μ
1 mil, thou	25.4 μ
2 mil, thou	50.8 μ
3 mil, thou	76.2 μ
5 mil, thou	127 μ
10 mil, thou	254 μ
20 mil, thou	508 μ
50 mil, thou	1,270 μ
100 mil, thou	2,540 μ
1,000 mil, thou	25,400 μ

How to Convert Mil to Micron

$$1 \text{ mi, thou} = 25.4 \mu$$
$$1 \mu = 0.0393700787 \text{ mil, thou}$$

Example: convert 15 mil, thou to μ :
 $15 \text{ mil, thou} = 15 \times 25.4 \mu = 381 \mu$